



IEC-61850 Based Substation Automation Solution

R. P. Gupta, Ph.D.

Deputy General Manager

Distribution Automation Research Centre

CG Global R&D Centre

Crompton Greaves Ltd.

Mumbai

Sep 23-24, 2008



Presentation

- **Introduction**
- **Substation Automation Architecture in compliance with IEC61850**
- **IEC61850 Protocol and standards**
- **Conceptual Realization of SA Function in IEC61850 Environment**
- **Details of IEDs and SCADA**
- **Additional Issues to address**
- **Conclusions**



Substation Automation: Def

Substation Automation is an integrated system that enables an electric utility to monitor, control and coordinate substation primary apparatus from remote location in real time.



Substation Automation Functions

- Data (analog & digital) Monitoring Function
- Switch Control Function
 - Switch Close/open operation from MCC, Station HMI, and BCU
 - Select-before-execute
 - Control interlock
 - Run time command cancellation
- Transformer Tap Changer Control
- Alarm Generation Function
- Printing and Log Report Function
- Self Supervision Function (watch dog feature)
- Substation Protection Systems through BPU's
- System Configuration
- System Security



Conventional Substation with Control & Relay Panels

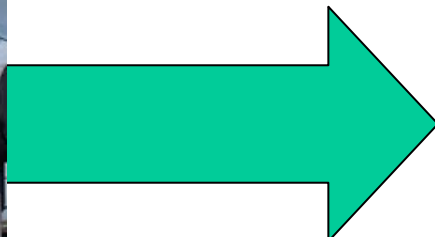

A Bunch of Hard Control-Wires



Control Room

Substation Automation using RTU

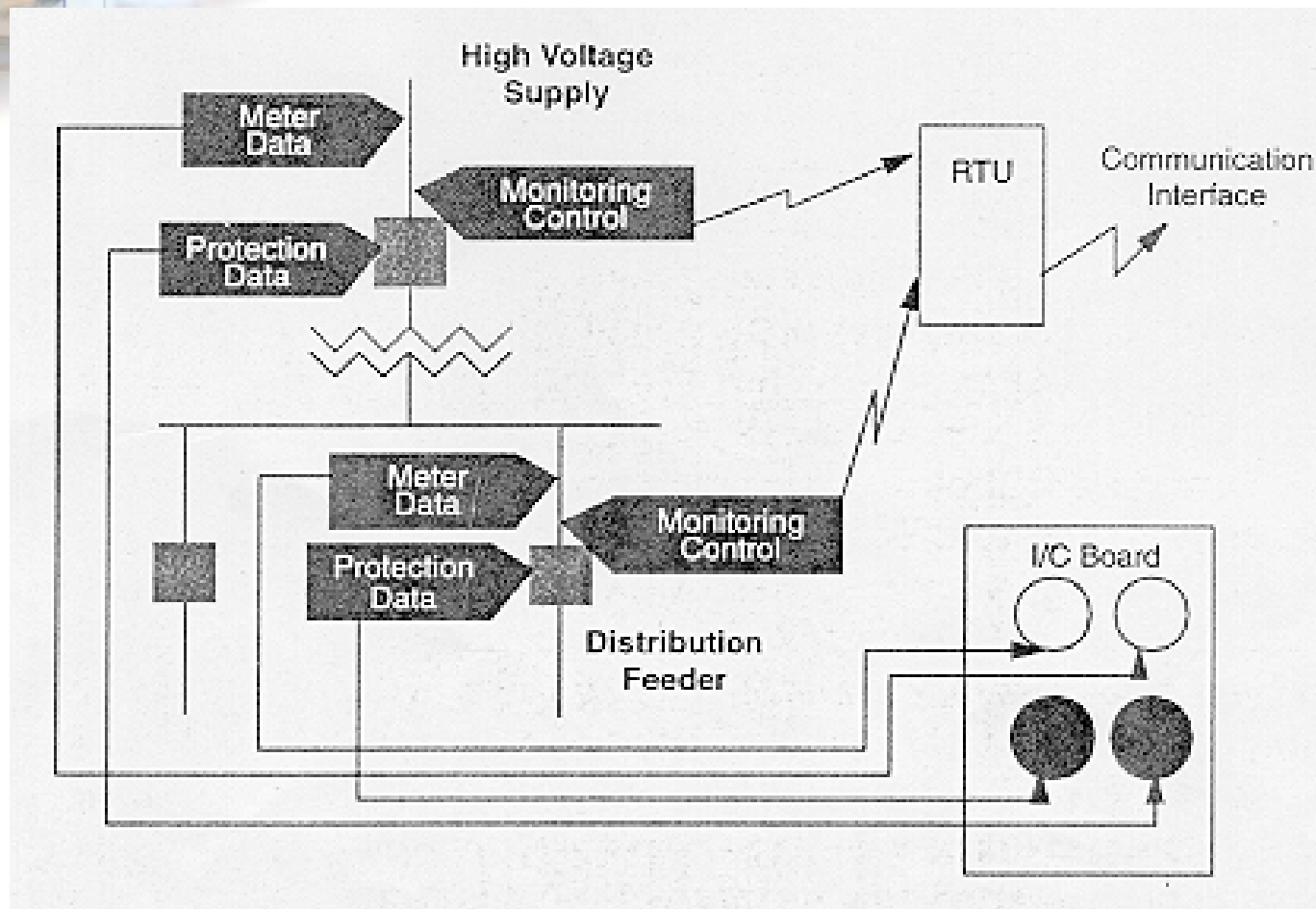

Substation Automation using RTU



Substation
Level
Intelligence

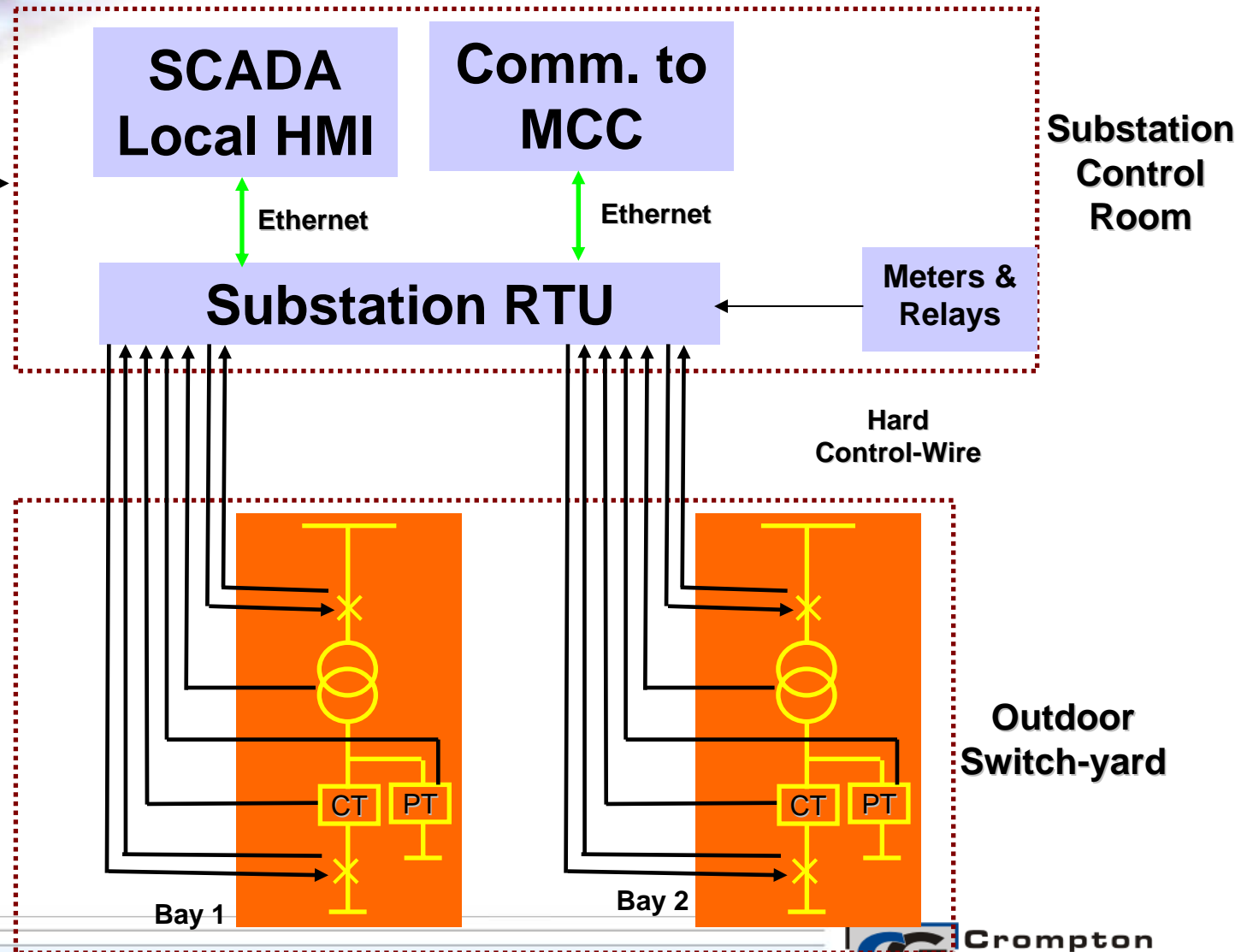

Substation Automation using IEDs

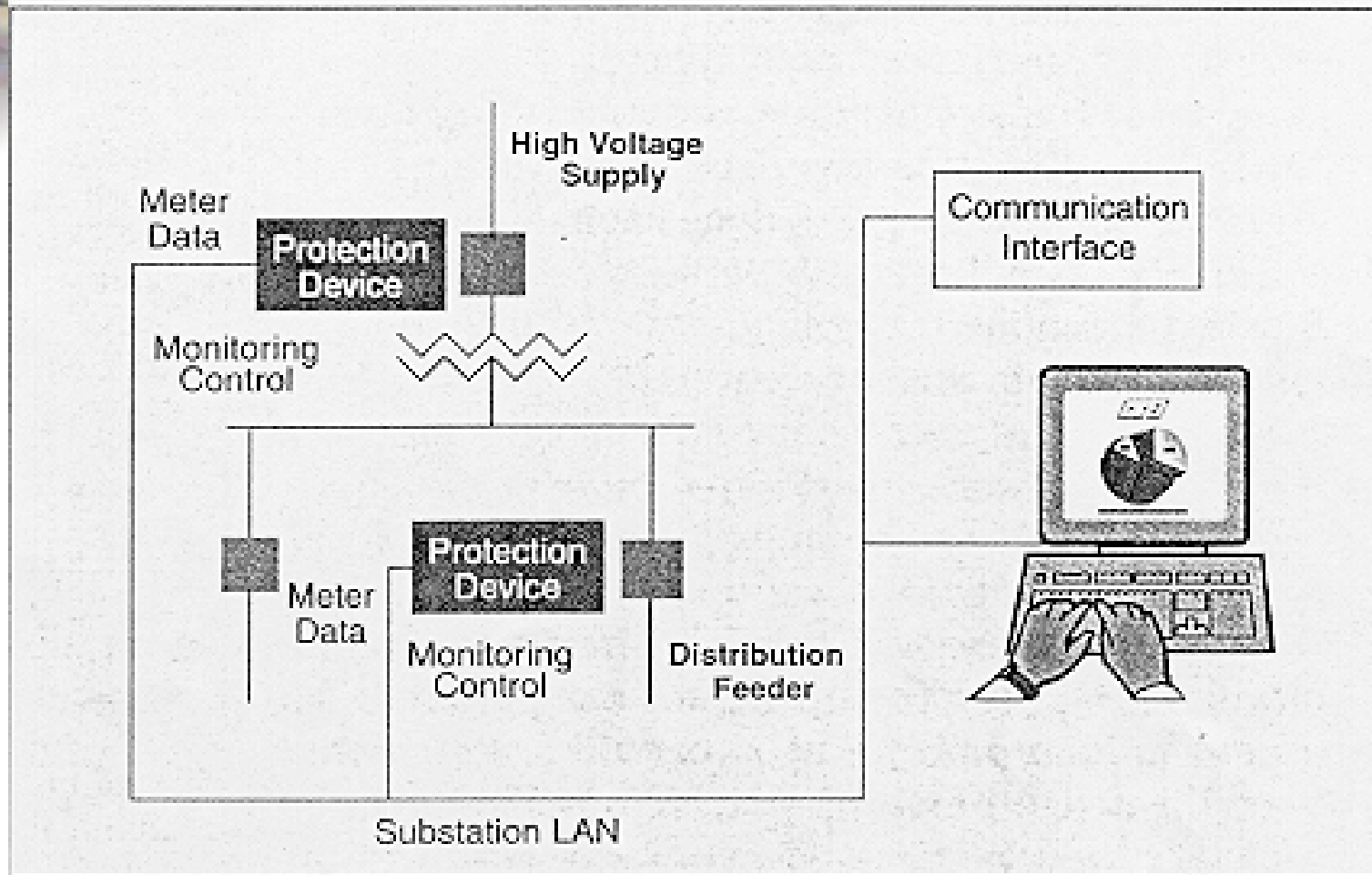



Automated Substation



Ethernet Wire

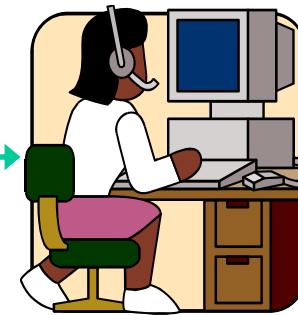

Control Room

Key Benefits

Reduction in the size of panels and control room

Reduction in hard control wirings

Efficient system operation using computer aided control decision

Reduction in O & M costs

IEC61850 Based Substation Automation



Substation
Level
Intelligence

Substation
Control
Room

SCADA
Computer

Ethernet

Ethernet
Switch

Ethernet

Bay
Level
Intelligence

Monitoring
& Control

Protection

Monitoring
& Control

Protection

Hard
Control-Wire

Outdoor
Switch-yard

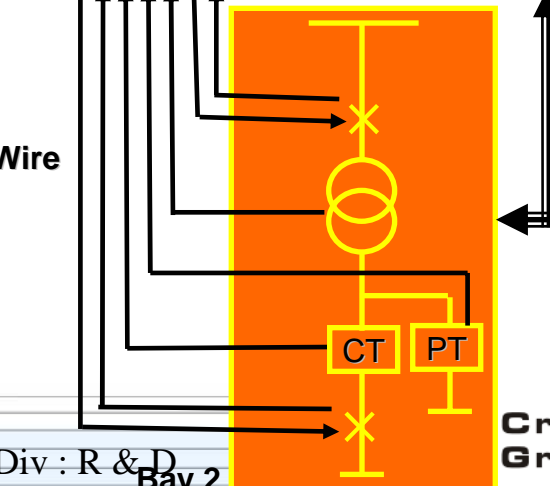
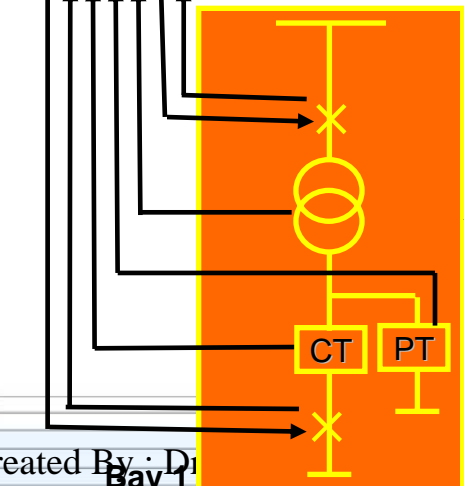

Crompton
Greaves

10/13/2008

Created By : Di

Dept : DARC Div : R & D

Document Class : H3

EVERYDAY SOLUTIONS

A Typical Substation Automation System

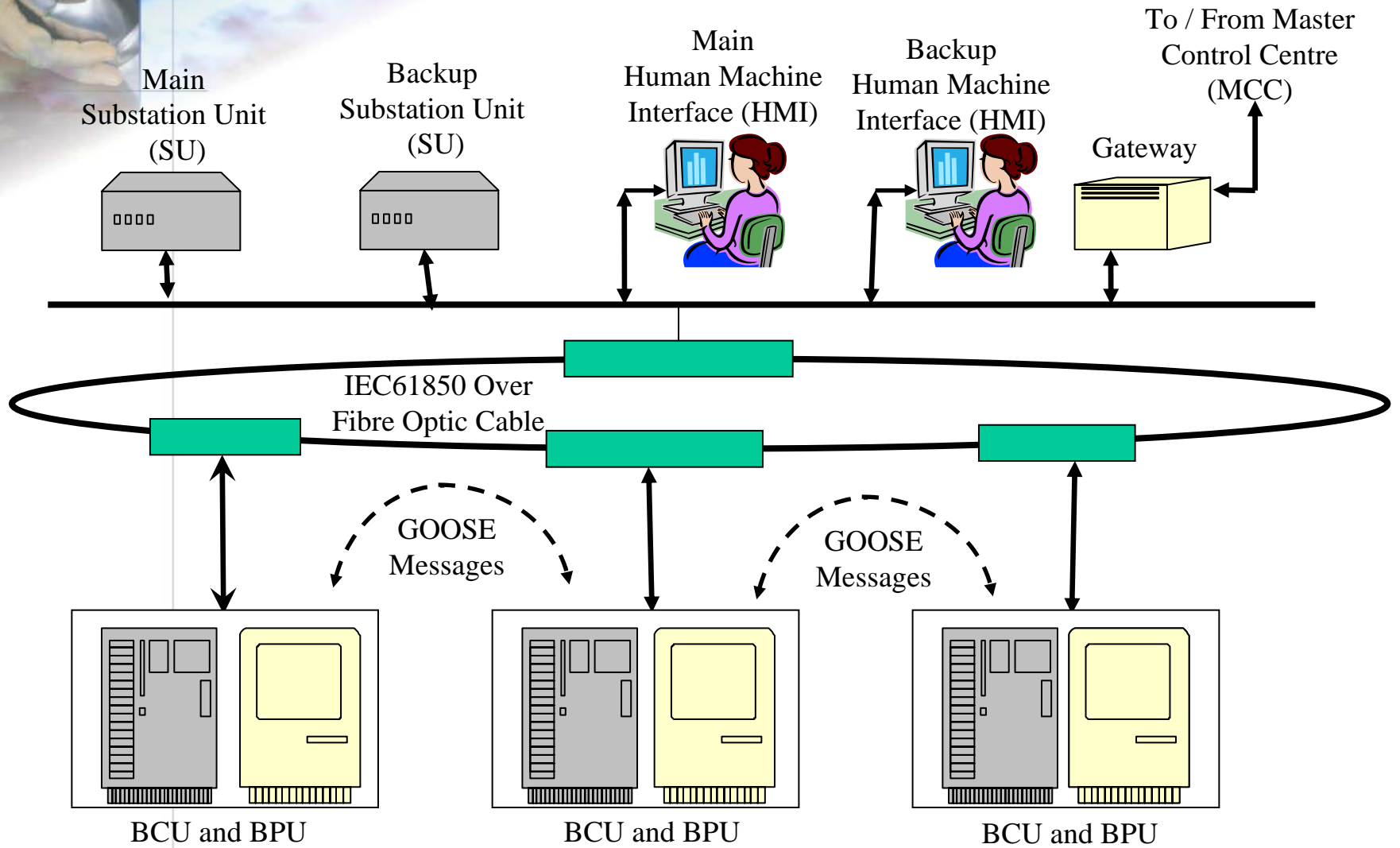

BCU : Bay Control Unit, BPU : Bay Protection Unit

A Typical Substation Automation System

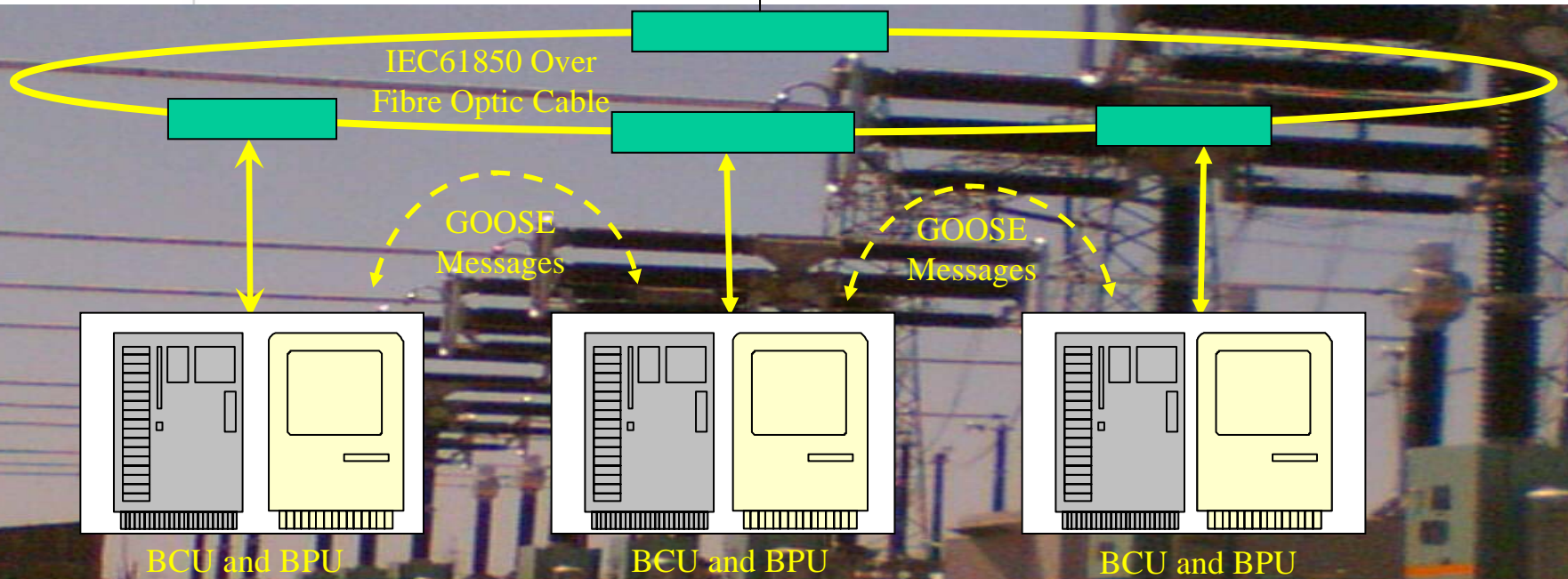
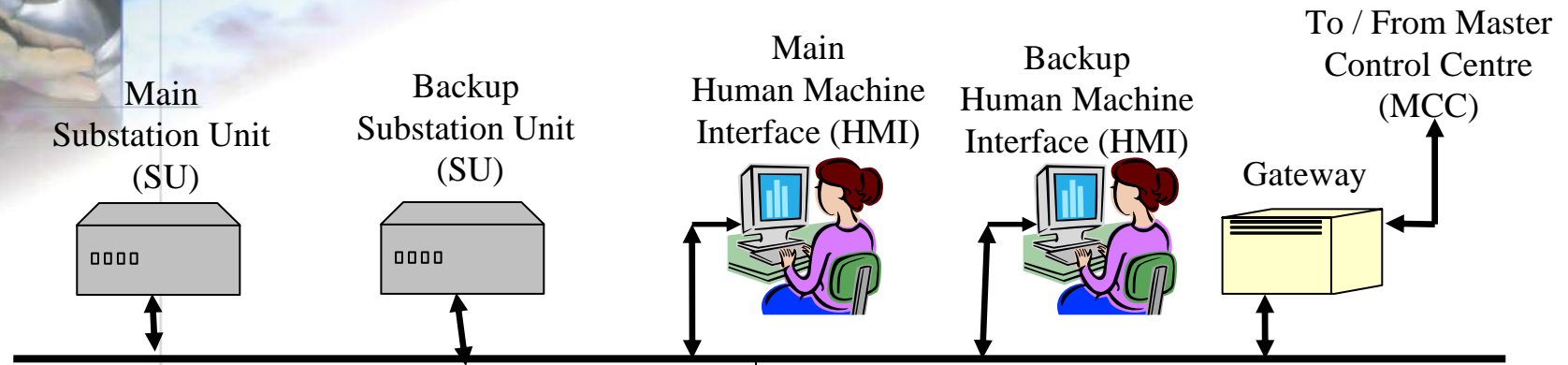

BCU : Bay Control Unit, BPU : Bay Protection Unit



Data Communication Protocol

- **Key Element for Substation Automation**
- **Protocol required to interpret the data at both ends of communication system in same way**
- **Conventional Protocol – Tag + Data**
(Tag mapping table required for system integration)
- **IEC61850 Protocol – Context + Data**
(Context is defined in the IEC61850 Standard.)



Integration & Interoperability (IED Config.)

- **Importing ICD File from IEDs**
- **IED configuration as per requirement using IED Configuration Tools**
- **Exporting CID File to IEDs**
- **Importing CID File from IEDs**



Integration & Interoperability (SCADA Config.)

- **SCADA system is configured using SCD file**
- **SCD consists of**
 - **Substation section**
 - **Communication sec**
 - **IED section**
 - **Data def section**



Integration & Interoperability

- **IED vendor has to provide IED, ICD file and configuration tool**
- **System integrator has to provide automated substation and corresponding SCD file**

IEC61850 Based Design Concept of Substation Automation

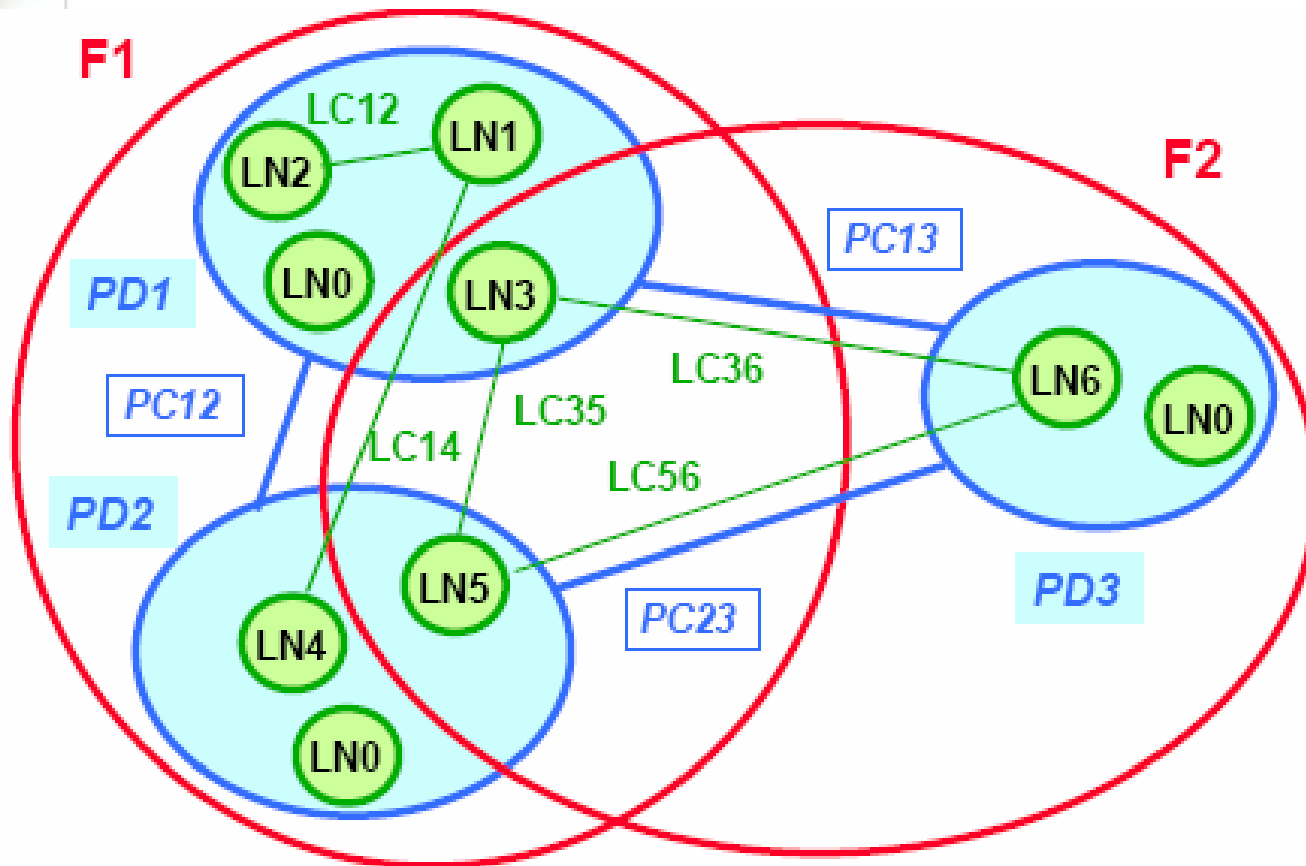

An Example of Protection system

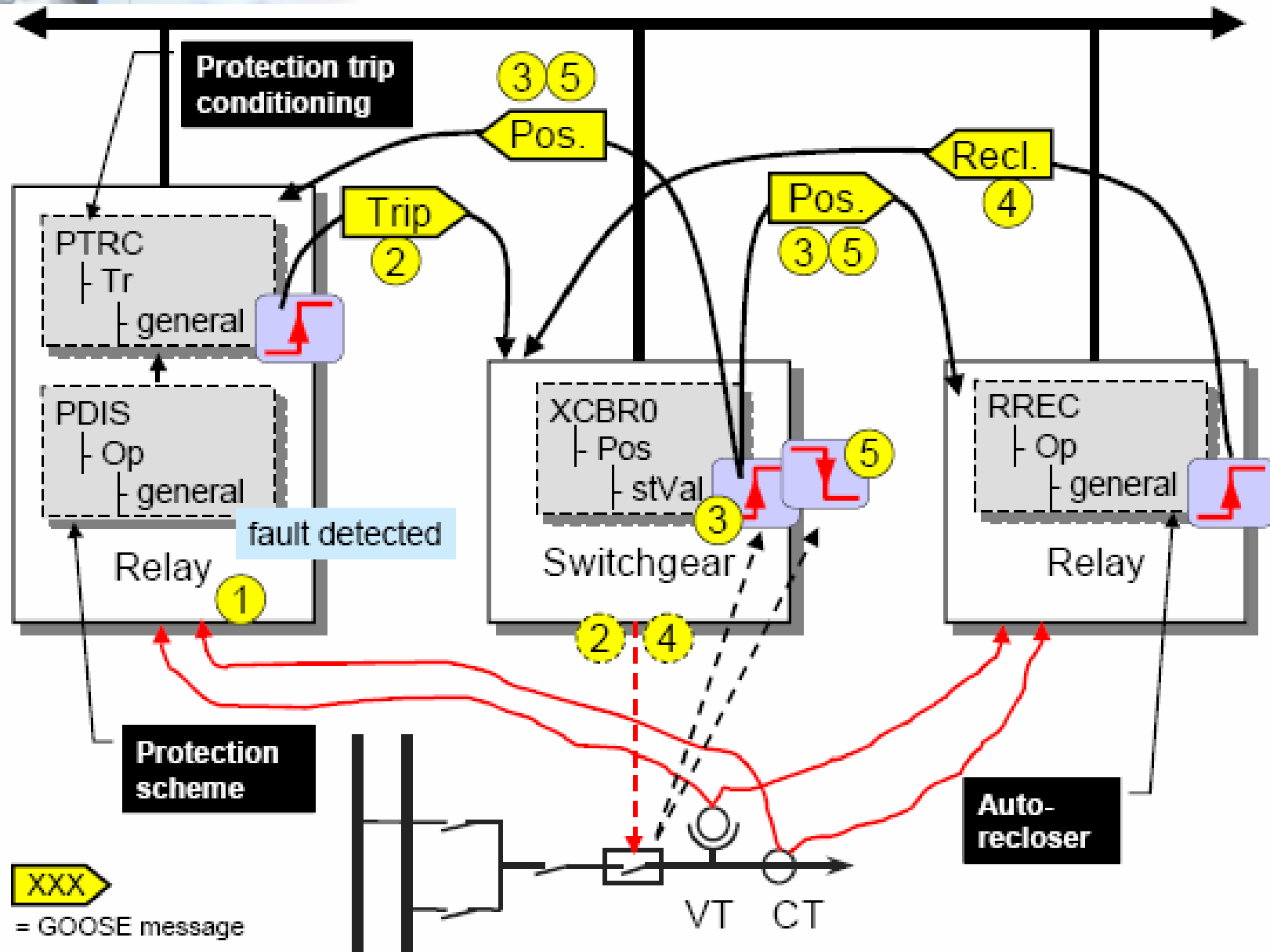

IEC61850 Based Data Modeling

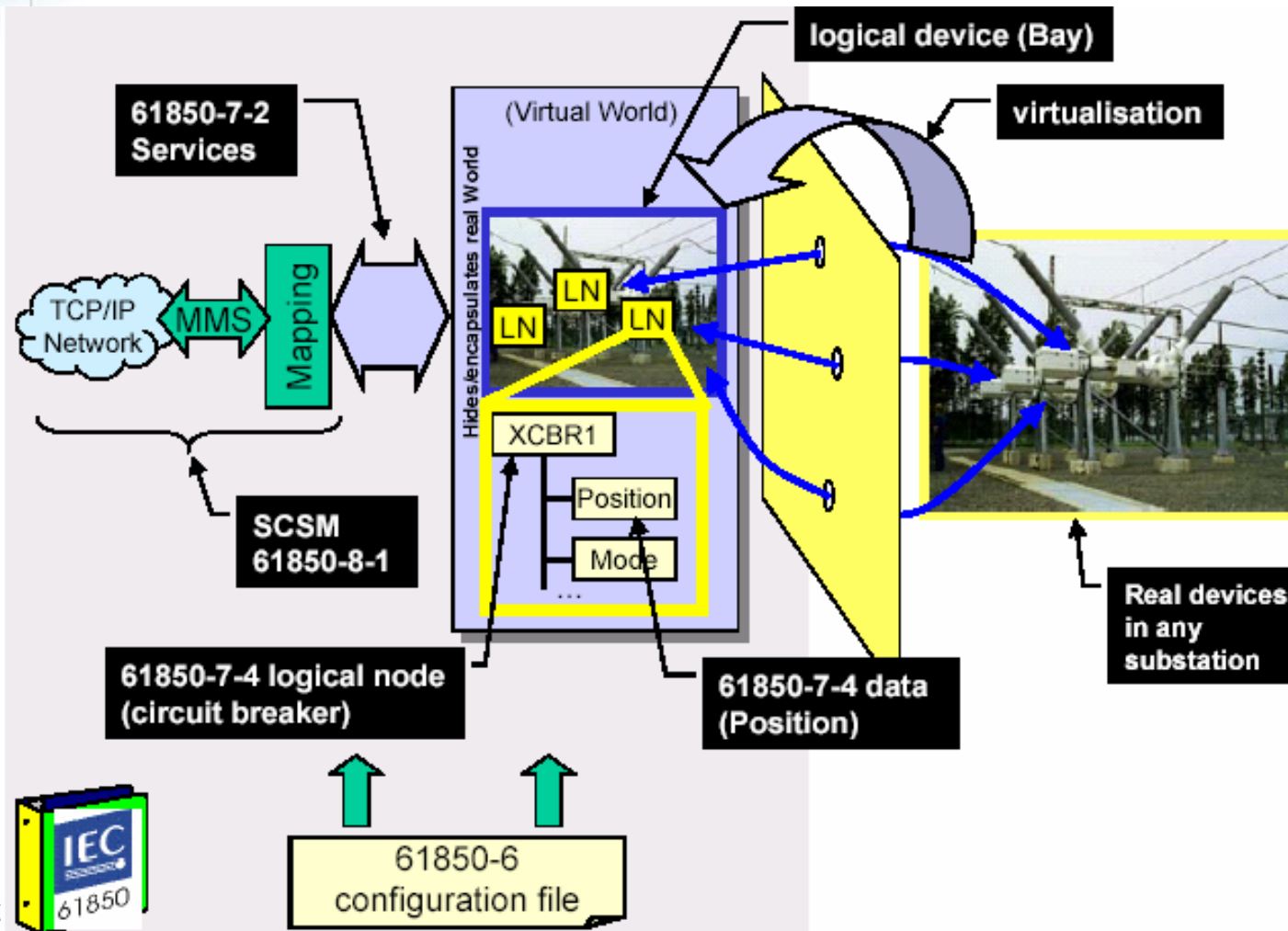

IEC61850 Based IEDs / Relays

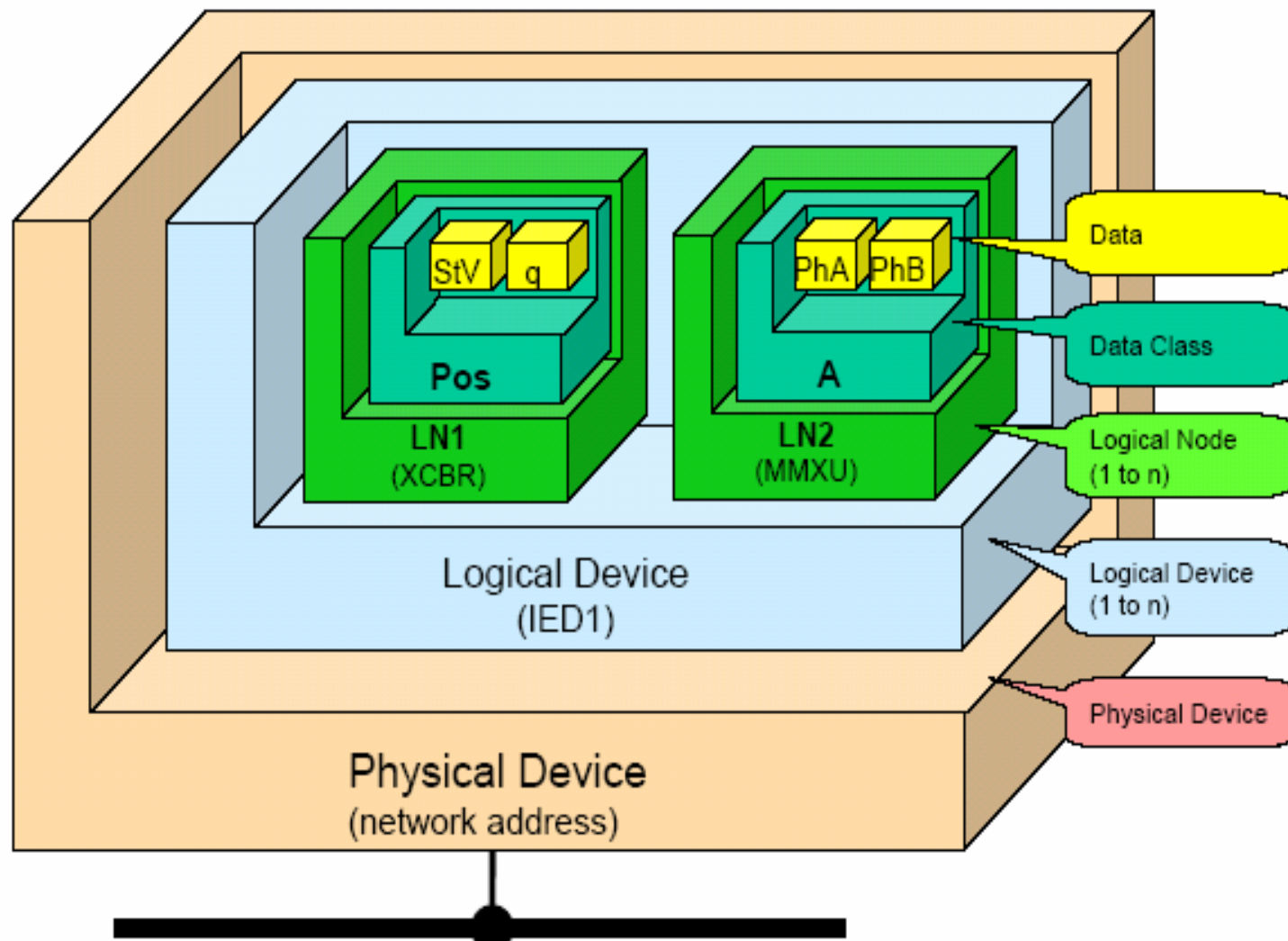

Category of Logical Nodes

13 different groups

Logical Node Groups	Group Designator	Description
System Logical Node	L	System specific information
Protection Function	P	Modelling of Protection function
Protection Related Function	R	LN's used for Protection function
Supervisory Control	C	Control functions
Generic References	G	Non predefined Generic functions
Interfacing and Archiving	I	Human Machine Interface
Automatic Control	A	Automatic Process Control
Metering and Measurement	M	Measurements of CTs and VTs etc.
Switchgear	X	LN's for Circuit Breakers
Instrument Transformer	T	Sampled values of CT and VT
Power Transformer	Y	LN's for Power transformer
Further Power System	Z	For auxiliary networks and batteries etc.
Sensors	S	Sensors for density, pressures etc.

Logical Node Classes: 90

Logical Node Groups	Group Designator	Number of Logical Node classes
System Logical Node	L	2
Protection Function	P	27
Protection Related Function	R	10
Supervisory Control	C	5
Generic References	G	3
Interfacing and Archiving	I	4
Automatic Control	A	4
Metering and Measurement	M	8
Switchgear	X	2
Instrument Transformer	T	2
Power Transformer	Y	4
Further Power System	Z	15
Sensors	S	4



Data Classes: 355

Categories of Data Classes	Number of Data Classes	Description
System Information	13	Information related to communication itself
Physical Device Information	11	Information related to IED
Measurands	66	List of Electrical units
Metered Values	14	Numerical Value of Electrical units
Controllable Data	36	Data which are changed by control commands
Status Information	85	Status of the process
Settings	130	Settings prior to function occurrence



Info under Logical Nodes

- Information under a Logical Node can be put in maximum five categories:

1. Common Logical Node Information
2. Status Information
3. Settings
4. Measured Values
5. Controls

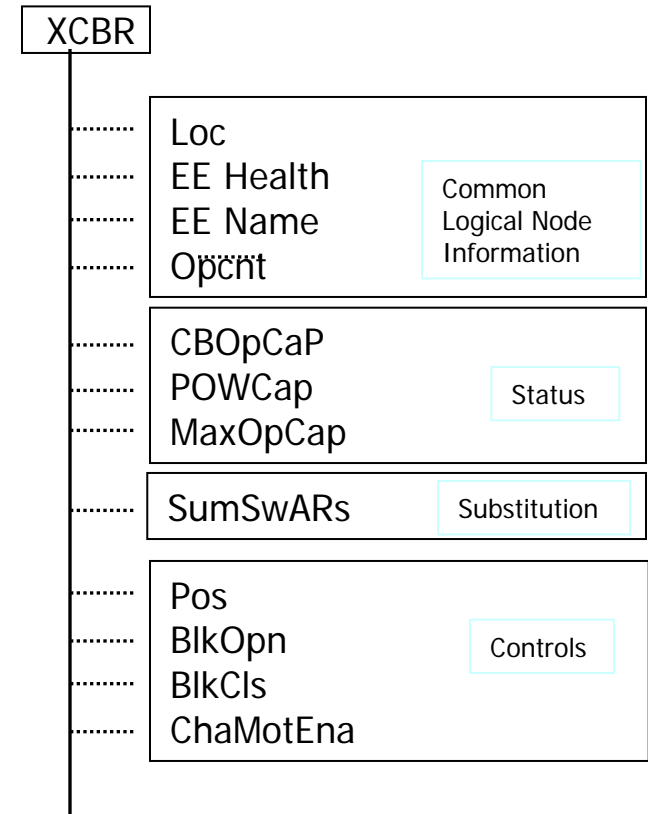

IEC61850 Based Data References

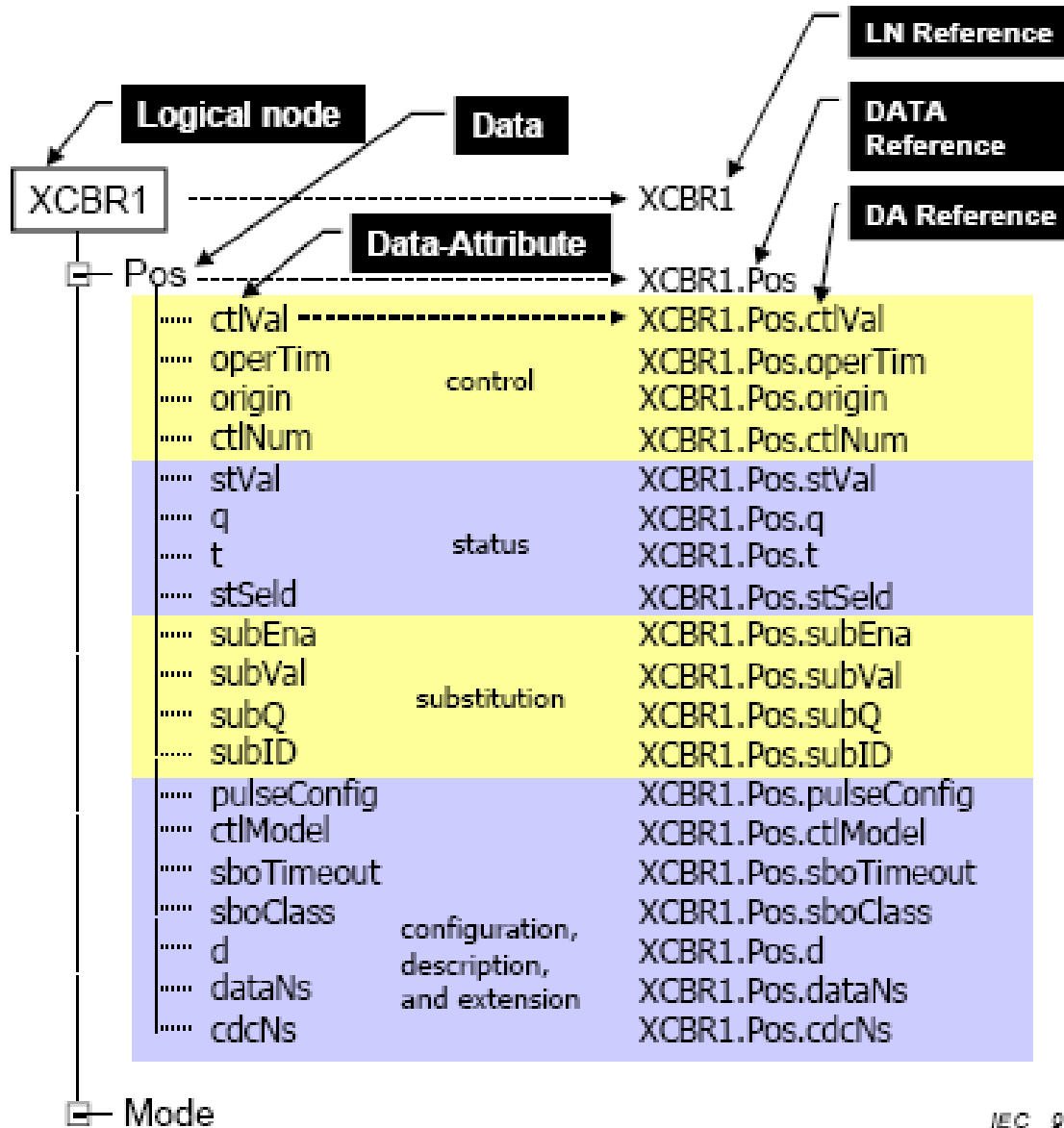



Accessing Data Think Window Explorer

Logical Node

Ex: IED1.XCBR1

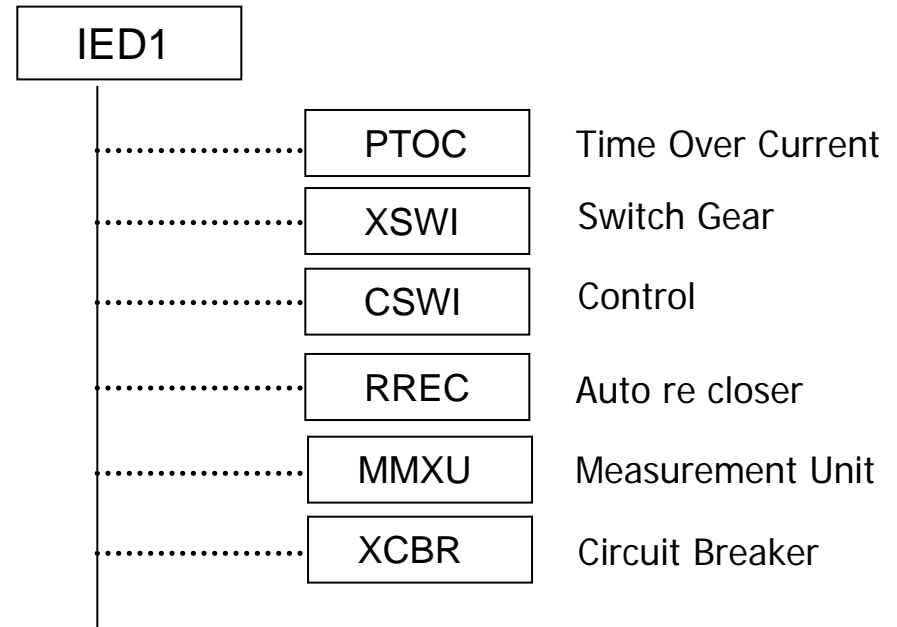



Accessing Data Think Window Explorer

- Accessing Data
from Logical Node
Ex: IED1.XCBR1.Pos

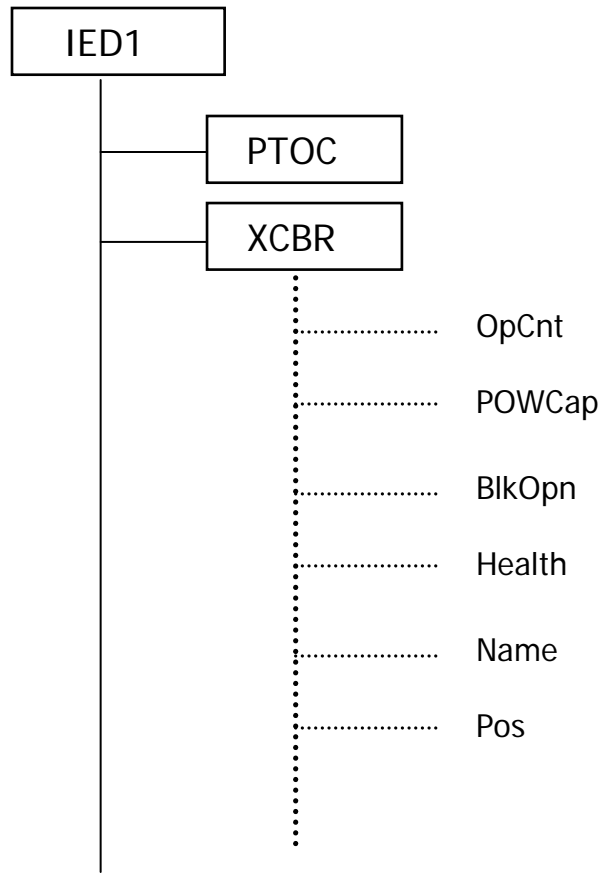

Accessing Data Think Window Explorer



- Data Attributes Accessed from Logical Node
- IED1.XCBR1.Pos.stval

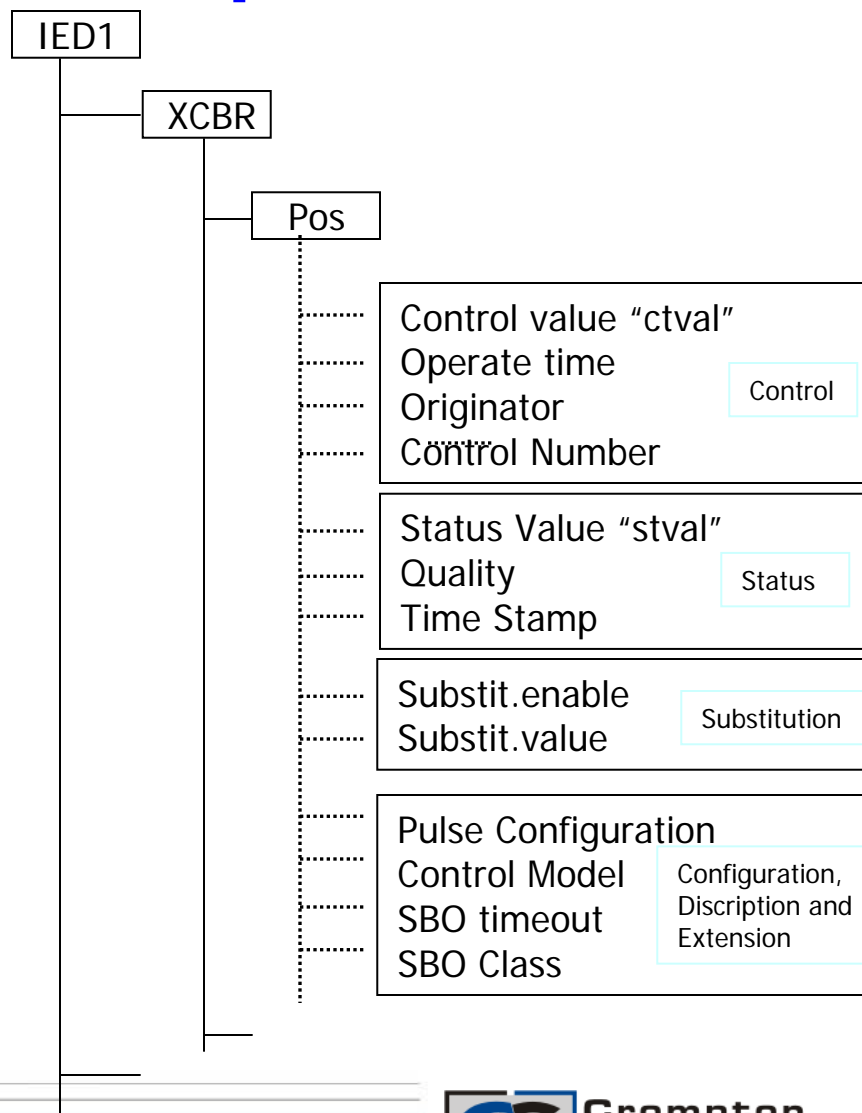

Example of Data Embedding

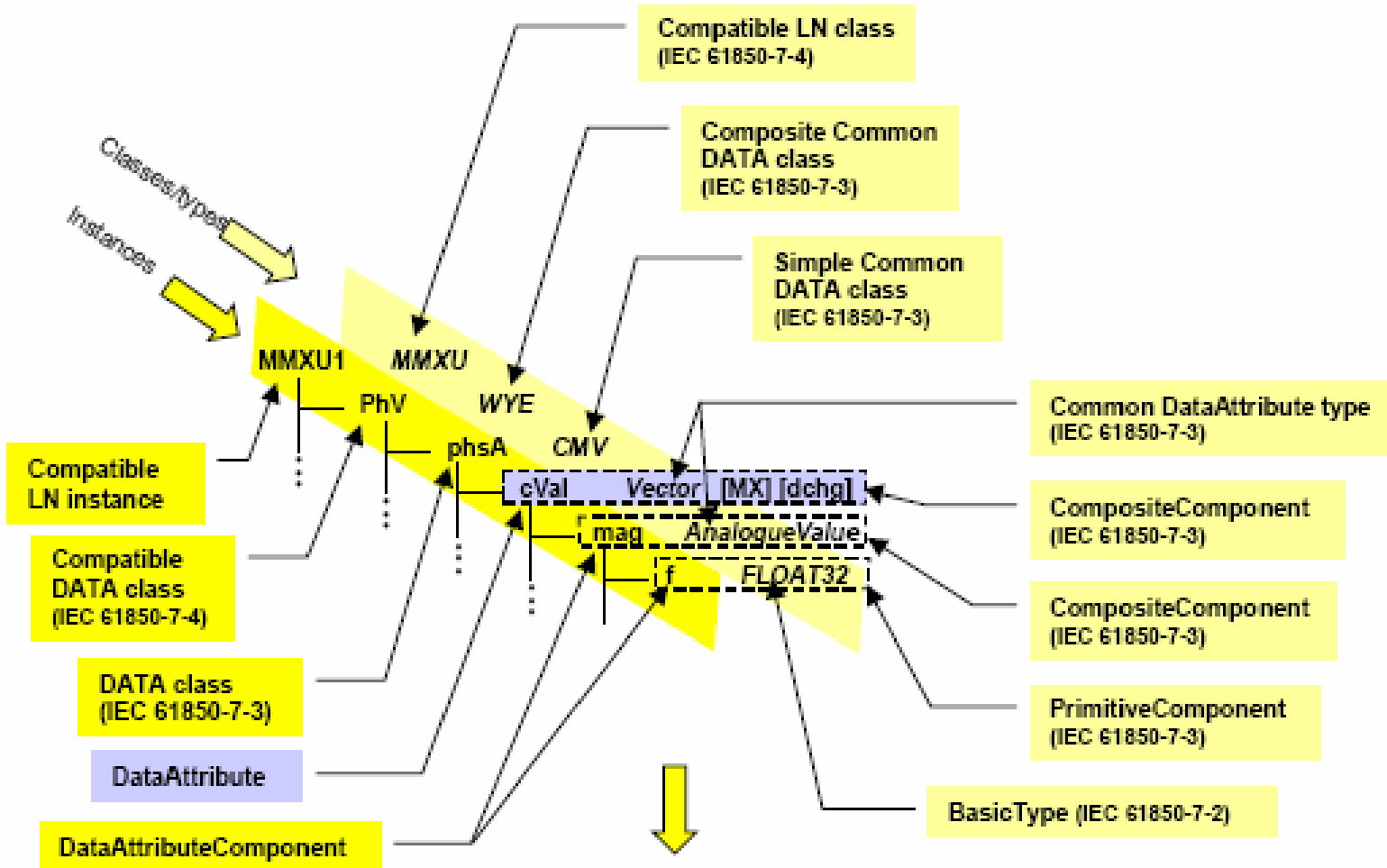

MMXU1.PhV	DataRef
MMXU1.PhV [MX]	MX functionally constrained Data (FCD)
MMXU1.PhV.PhsA	DataRef
MMXU1.PhV.PhsA.cVal	DataAttrRef
MMXU1.PhV.PhsA.cVal [MX]	MX functionally constrained DataAttribute (FCDA)
MMXU1.PhV.PhsA.cVal.mag	DACComponentRef
MMXU1.PhV.PhsA.cVal.mag.f	DACComponentRef

DataRef
 MX functionally constrained Data (FCD)
 DataRef
 DataAttrRef
 MX functionally constrained DataAttribute (FCDA)
 DACComponentRef
 DACComponentRef



IEC61850 Based Data Communication Stacks

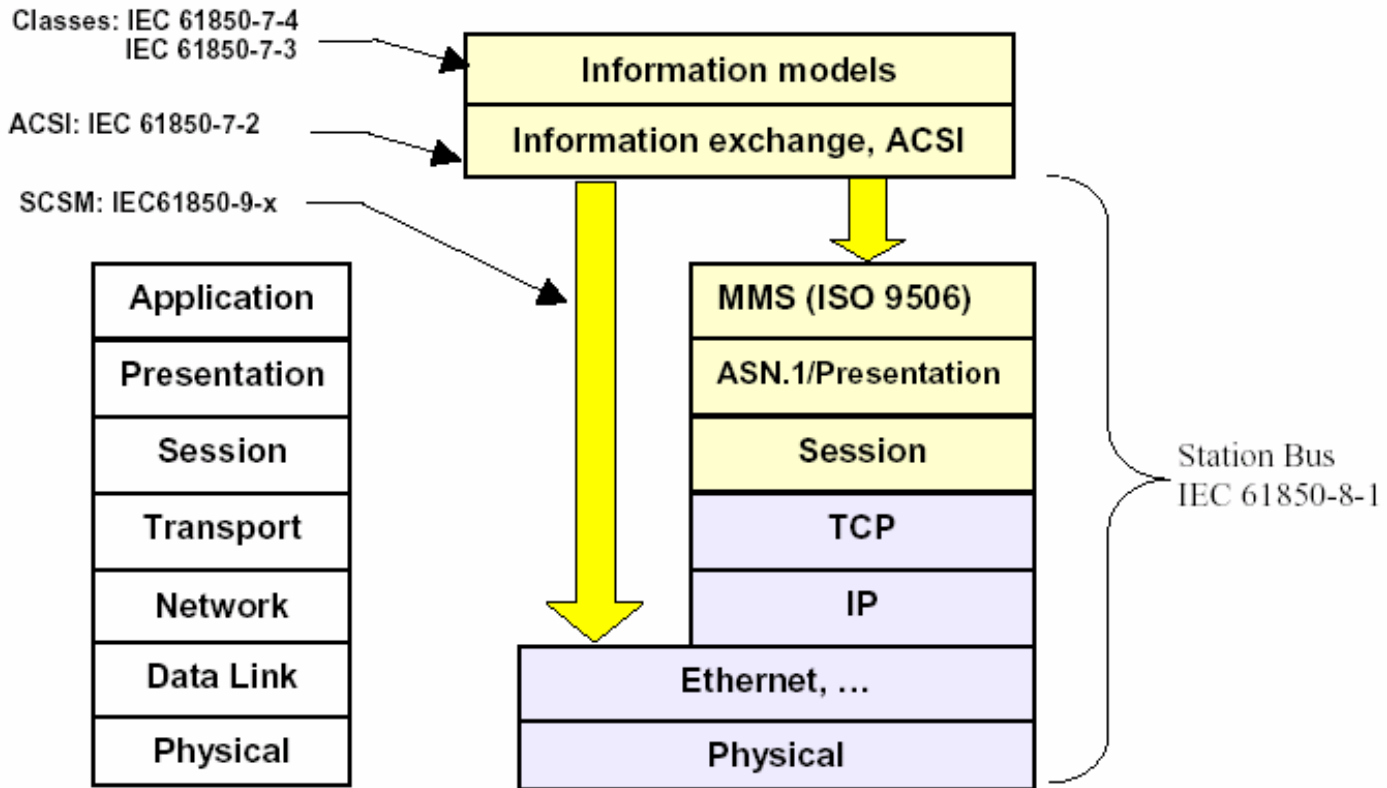

Data Exchange Between SCADA Computer and IEDs



**IEC61850
Client**

1. Data on request
2. Data by exception

**IEC61850
Server**

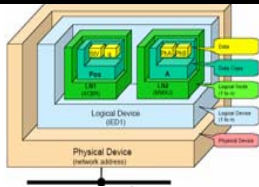

**IEC61850
Server**

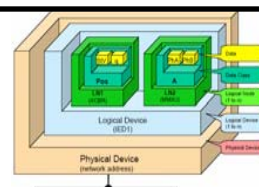

**IEC61850
Server**

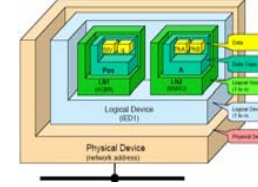



Data Exchange Between SCADA Computer and IEDs

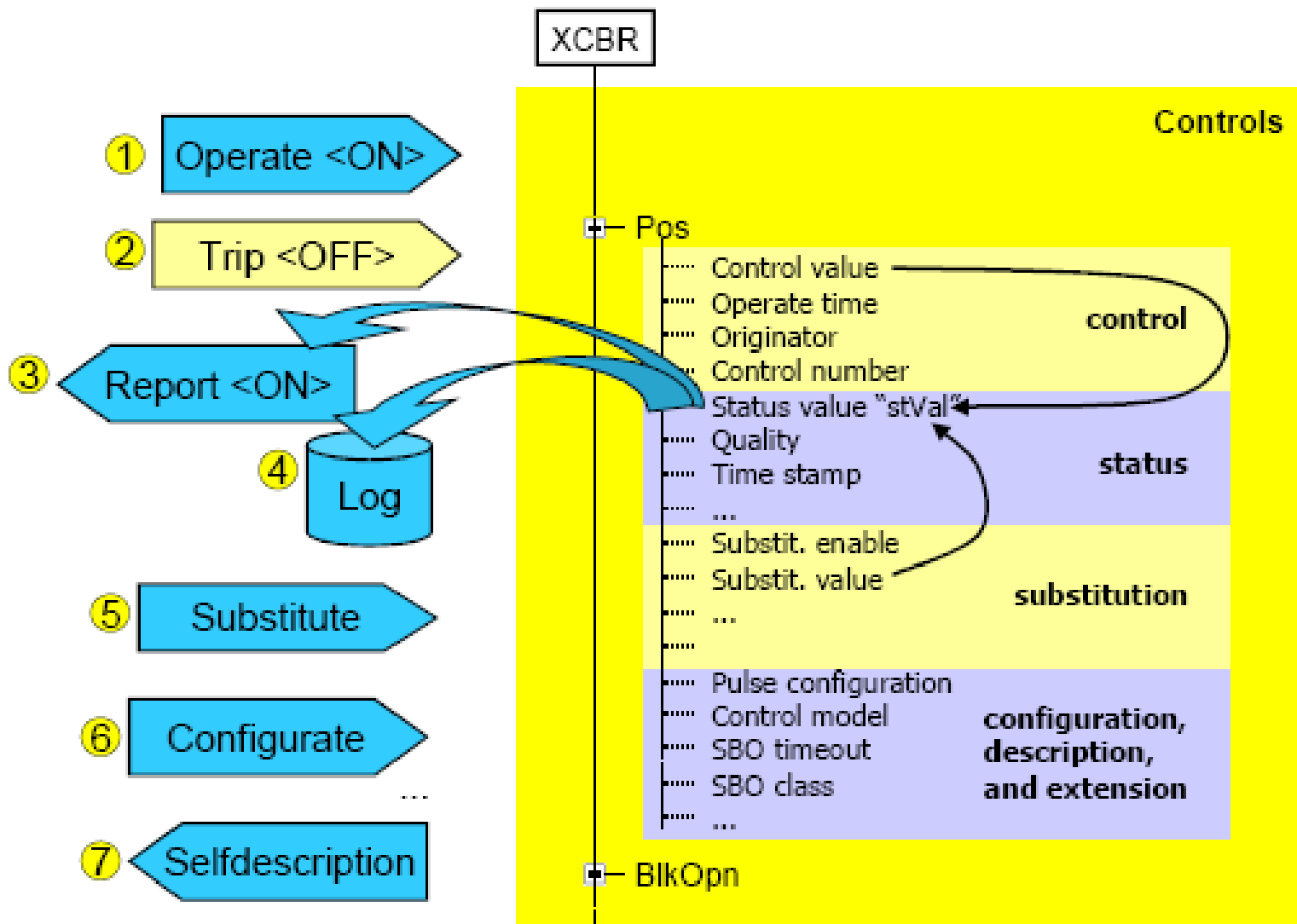



Input and Output of IEDs

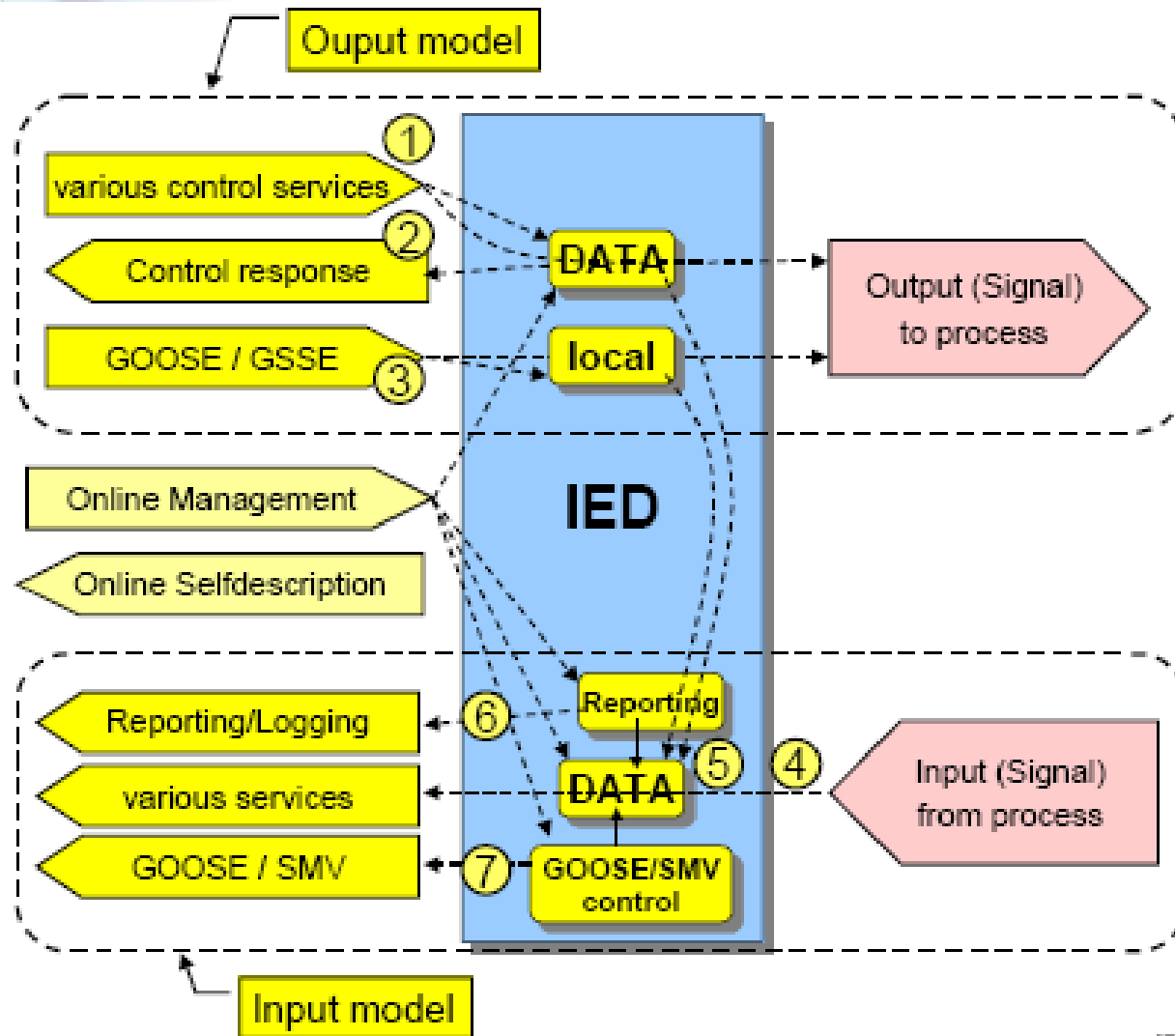



Output Model

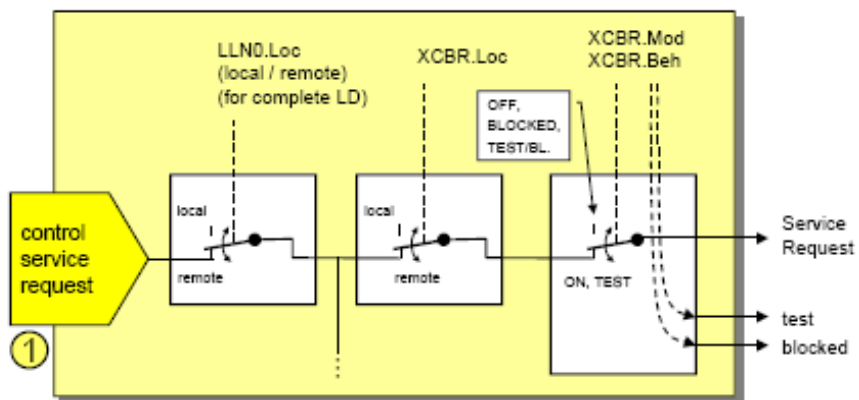

Step-1

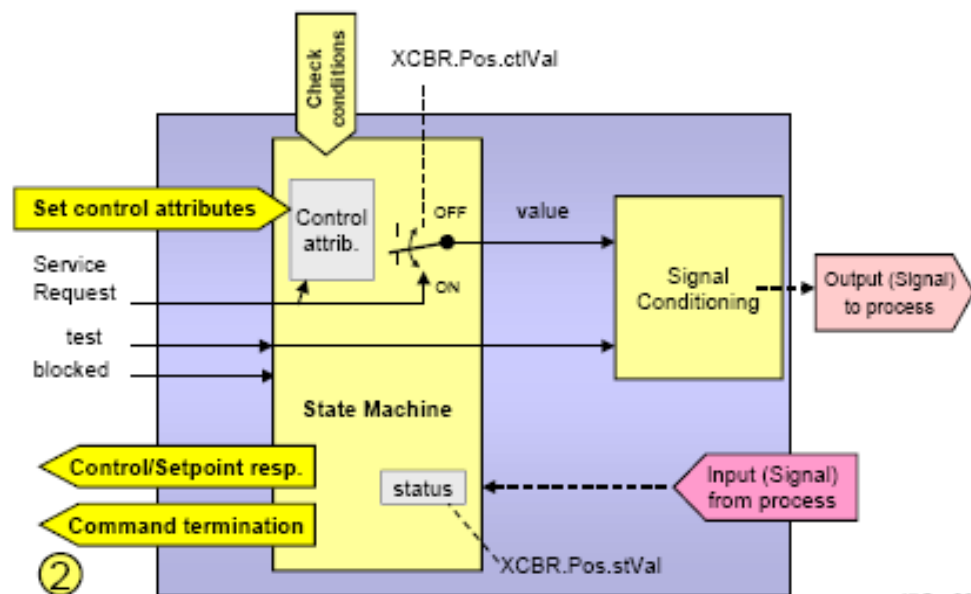

Step-2

IEC61850 Based Reporting & Logging Mechanism

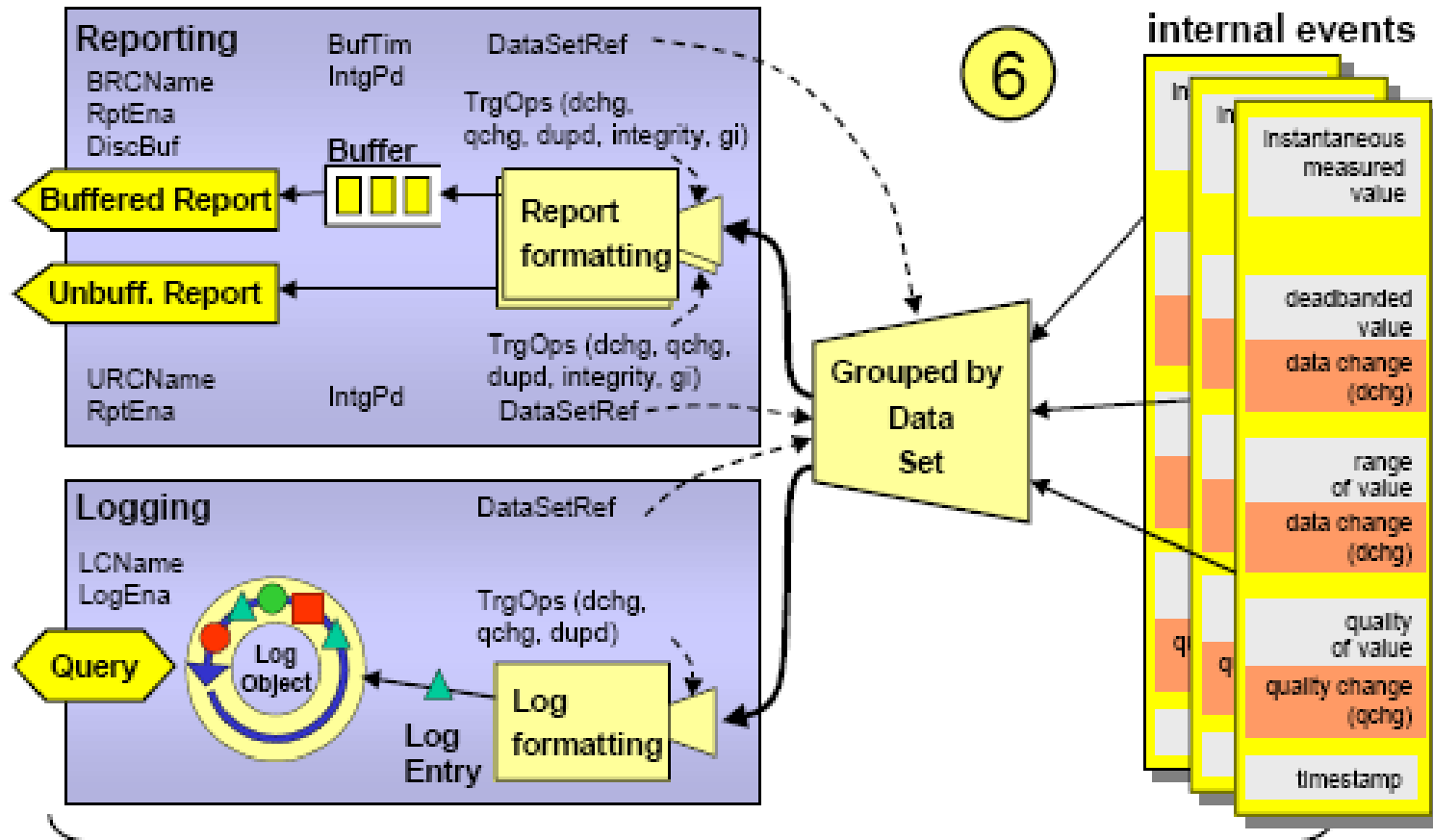

IEC 61850-7-2

IEC 943/03

IEC61850 Based Reporting Mechanism

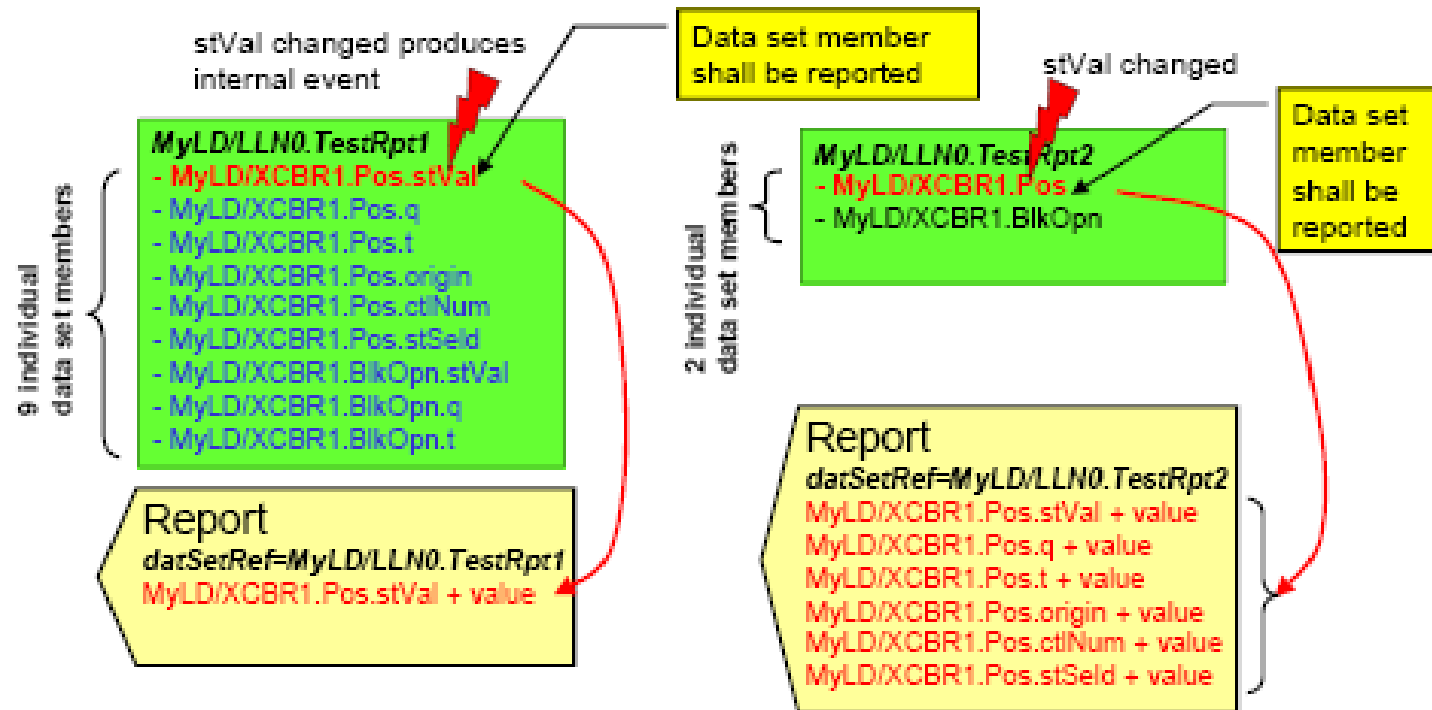

NOTE All data attributes are functionally constrained by FC=ST.

IEC 944/03



Client-Server Transaction for Reporting Mechanism

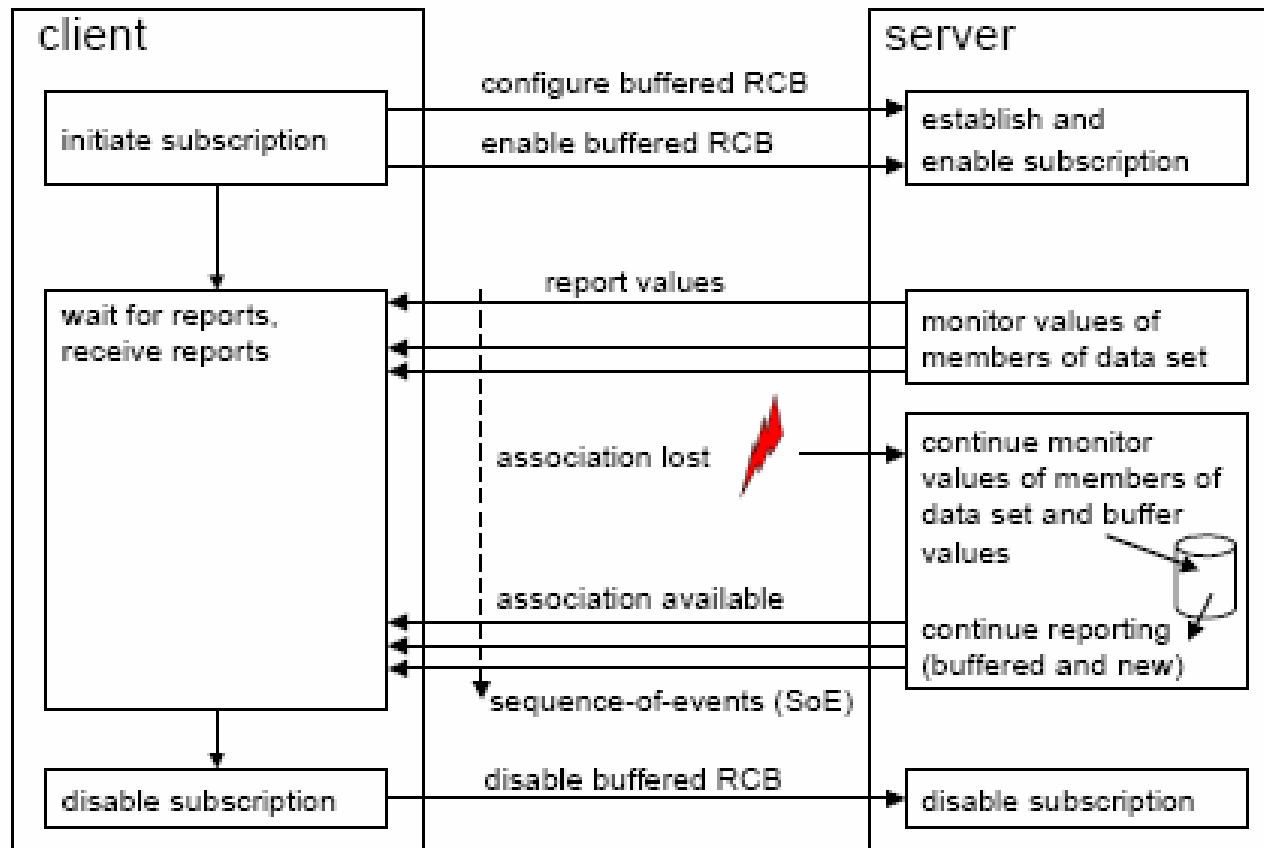



Reporting Data Sequence

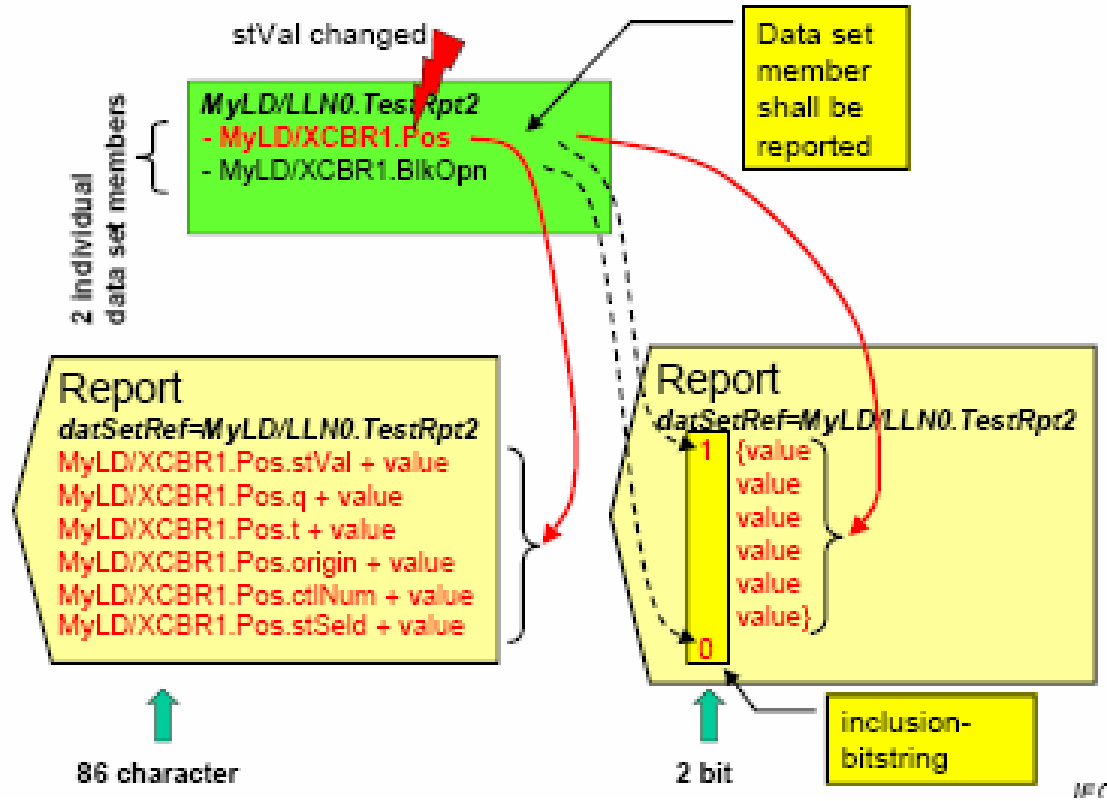

Client-Server Transaction for Logging Mechanism

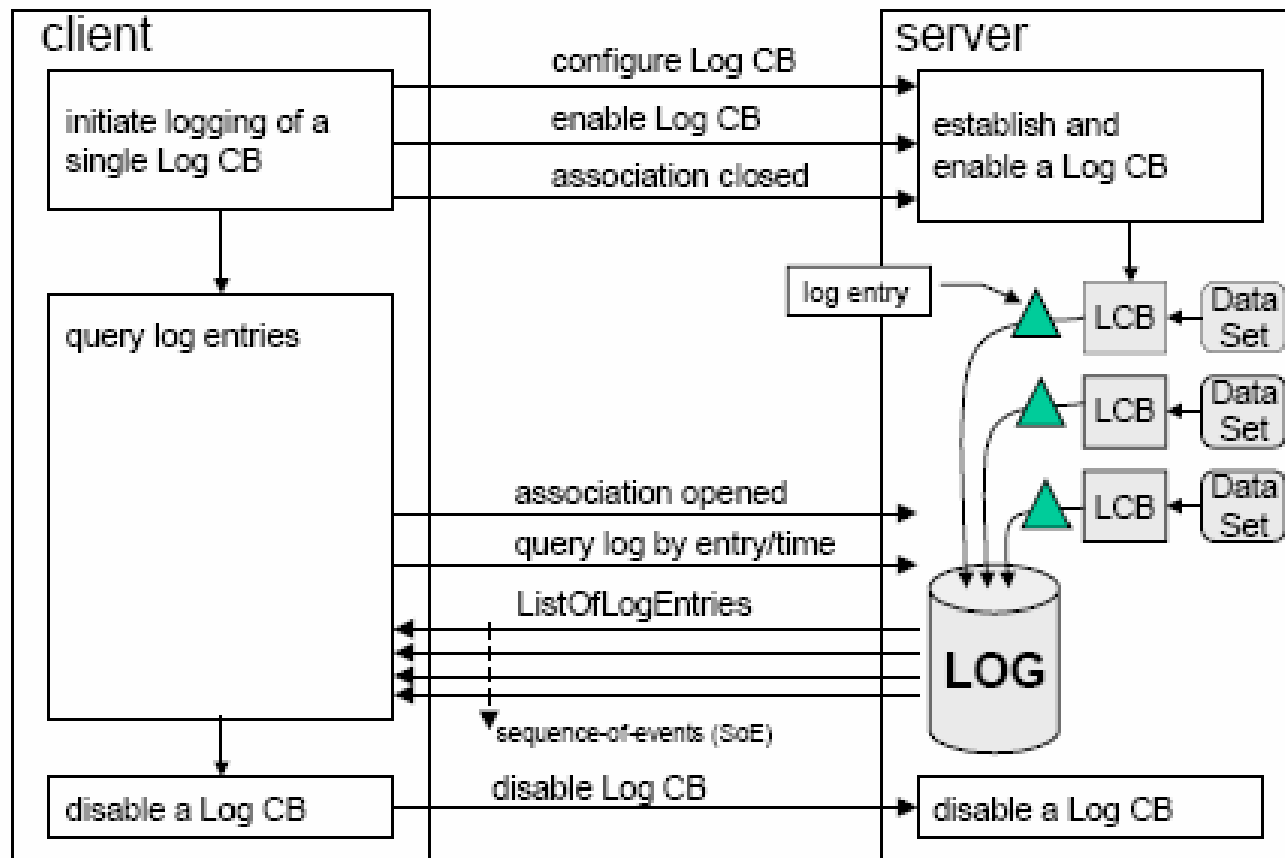



IED to IED Communication

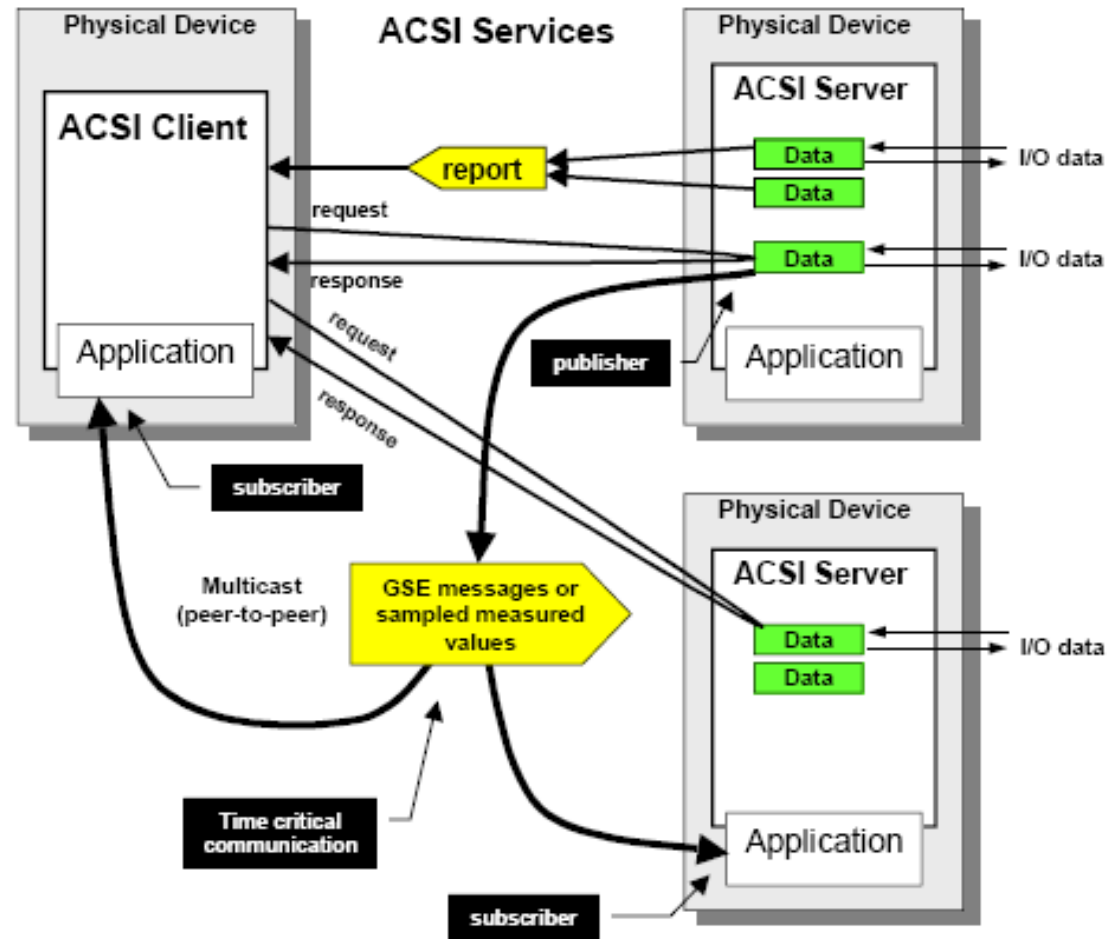

Building Block of Server system

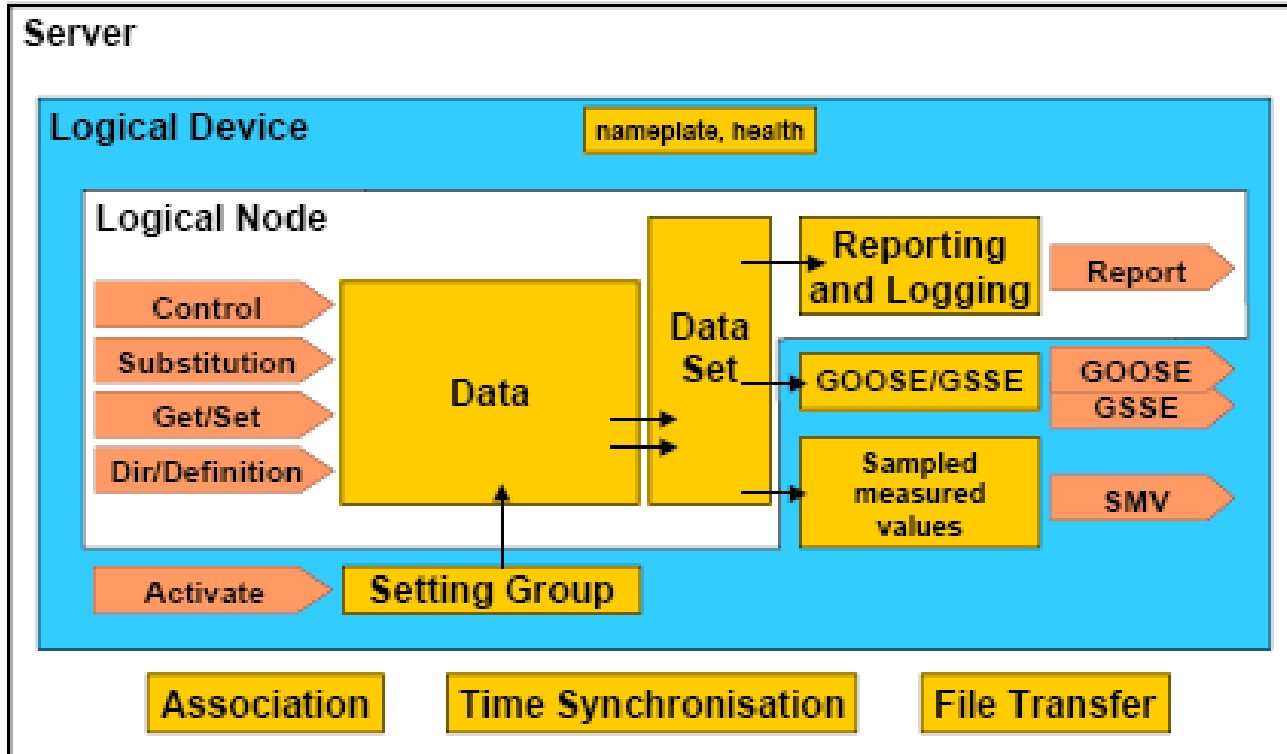



Additional Issues

IEEE Working Groups are focusing on ...

- **Cyber Security of IEDs and SCADA System**
- **Common Data Format for IED configuration**
- **Common Data Format for events and logs**
- **Plug & Play Supported Open Hardware for IEDs**



Conclusions

- **IEC61850 provides full interoperability feature**
- **3rd party IED can be easily integrated into the existing substation using ICD and CID files**



Thanks ...