

IEC61850 Based Substation Automation

Dr. R. P. Gupta, *Member, IEEE*

Abstract— Electric power utilities, at present, are facing problem of interoperability among Intelligent Electronic Devices (IEDs) supplied from different companies during the expansion of an existing electric substation. An attempt is in progress to build a universal protocol to eliminate the problem of interoperability. In this context, European protocol “International Electro-technical Commission (IEC) 61850” is getting popularity all over the world for flexible data communication across the IEDs in an electric power substation. This paper describes a conceptual substation automation scheme for the future using the IEC-61850 protocol to ensure interoperability among the various devices.

Index Terms—Communication Protocols, IEC-61850, Substation Automation.

I. INTRODUCTION

Substation Automation (SA) is a system to enable an electric utility to remotely monitor, control and coordinate the distribution components installed in the substation. High-speed microprocessor based Remote Terminals Units (RTUs) or Intelligent Electronic Devices (IEDs) are used for substation automation and protection. These IEDs are installed in strategic locations for collection of system data and automatic protection of substation equipments. Data communication between the control centre and IEDs in remote locations and among the IEDs becomes an important issue to realize the substation automation functions. Various protocols are used for tele-control purpose, but none of them fully support the interoperability among IEDs supplied by different vendors in the substation. These protocols are Modbus, Modbus Plus, DNP 3.0, and IEC 60870. Though these protocols are used at utility level, these suffer from some shortcomings. Modbus and Modbus Plus are suitable mainly for serial data communication and not optimized for communication over Ethernet. In DNP 3.0, data packet loses its context. Data context provides association of data packet with data element. DNP 3.0 is a subset of IEC 60870. Looking at these shortcomings, an American standard has emerged in the form of Utility Communication Architecture (UCA) 2.0. Further, some domain specific features of substation have been added to UCA 2.0 to make it suitable for substation automation and a new protocol IEC-61850 is finally evolving [1]. A part of this protocol has already been published and

other parts are under development by a European agency. IEC-61850 ensures the interoperability among various substation automation components supplied by different vendors. IEC-61850 is a superset of UCA 2.0 [2]. IEC 61850 is an all-encompassing data communication protocol that is suitable for several applications. This paper presents a conceptual adaptation of the IEC 61850 protocol for substation automation in the future.

II. BASIC APPROACH

The functions performed by Substation Automation (SA) system are in, general, switch control, data monitoring, protection etc. In IEC-61850, these functions are broken into low-level functions called sub-functions. Each sub-function is performed by the IED installed in the substation. Each IED can perform one or many sub functions. A set of sub-functions is integrated together to realize a substation automation function. These communicate with each other through Local Area Network in the substation. Specific syntax and semantics are defined for communication between sub-functions. All the possible sub-functions have been standardized in IEC-61850. Information produced and required by each substation is given in the IEC-61850 standard.

III. FUNCTIONAL ARCHITECTURE

The main substation automation (SA) function consists of several sub-functions which are appropriately interfaced. These sub-functions are known as Logical Nodes (LN). Logical nodes reside in the IED which is also called a Logical Device (LD). One logical device (IED1) holds one or multiple Logical Nodes (LN1 and LN2) as shown in Fig. 1 [3].

A logical node is realized through an object class, called logical node class. For example, XCBR is a logical node class for monitoring and operation of circuit breaker. A logical node class consists of a set of data belonging to different class. For example data “Pos” of data class type “DPC” is a member of logical node class “XCBR” [4]. Further each data class inside a logical node class consists of a set of data attributes. For example, data class “DPC” consists of data attributes given by Control value “ctlVal”, Operating time “operTime”, etc. [5]. These data attributes are used as necessary parameters to perform the functions. For example, XCBR1.Pos.stVal represents the close/open status of circuit breaker “XCBR1”. The sub functions are assigned at three levels as shown in Fig. 2: (i) Process level (ii) Bay level (iii) Station level [6].

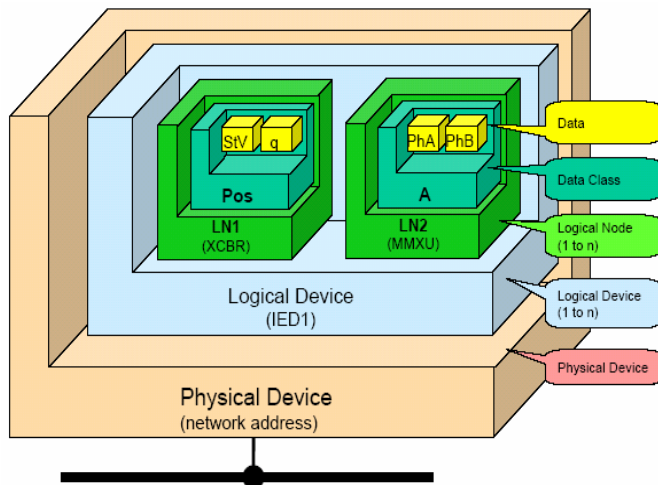

FIG. 1 DEVICES, NODES, CLASSES AND DATA

unit. Protection unit and Control unit are bay level devices. Bay level devices collect data from the same bay and/or from different bays and perform actions on the primary equipment in its own bay.

Station level functions are of two types.

- (i) *Process related functions* act on the data from multiple bays or substation level database. These functions are used to submit the control commands for the primary equipment (Circuit breakers) and collect the substation data like voltage, current, power factor etc. from the bay level devices. As described above, each bay includes one primary equipment such as transformers, feeders etc.
- (ii) *Interface related functions* enable interactive interface of the substation automation system to the local station operator HMI (Human Machine Interface), to a remote control centre TCI (Tele Control Interface) or to the remote monitoring centre for monitoring and maintenance TMI (Tele Monitoring Interface).

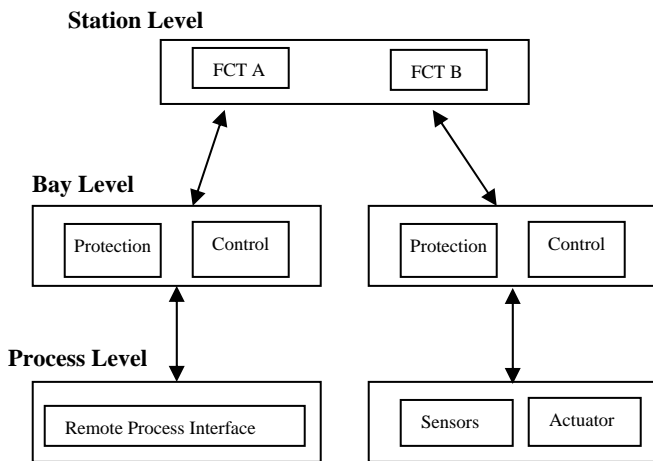

Fig. 2 Levels defined in IEC-61850

Process level function extracts the information from sensors/transducers in the substation and to send them to upper level device, called bay level device. The other major task of process level function is to receive the control command from bay level device and execute it at the appropriate switch level.

Bay level functions acquire the data from the bay and then mainly act on the primary (power circuit) equipment of the bay. The different conceptual subparts of a substation are encircled by dotted line in Fig. 3. These subparts are called bays and designated by Bay1 to Bay7 as shown in Fig. 3. For example, a transformer with its related switchgear between the two busbars representing the two voltage levels forms one bay, designated by Bay3. The Current Transformer (CT) and Potential Transformer (PT) are an integral part of Bay3 for monitoring, control and protection of the transformer. The CT, PT and actuator are connected to protection and control unit via merging unit. Merging unit is a device to collect the instantaneous values of current and voltage from CT and PT, sample the same and send them to the protection and controls

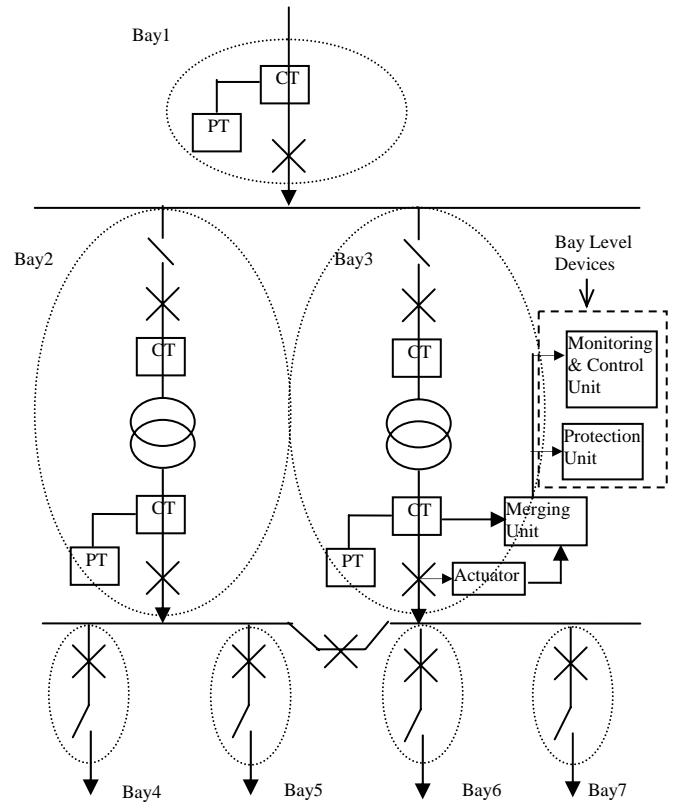

Fig. 3 Conceptual Substation Bays

A total of 90 logical nodes or sub-functions are defined in IEC 61850 and all of them are distributed at these three levels – (i) Process level (ii) Bay level (iii) Station level, according to their functionalities. Logical nodes are connected with each other through dedicated virtual links (also called Logical Connection) to exchange the data. A logical connection is realized through physical connections. In the conceptual

substation automation scheme, the physical connection between IEDs is realized through Ethernet cable and computer networking switches. Each such network switch forms a network node.

IV. FUTURE SUBSTATION AUTOMATION SYSTEM

There are basically two types of equipment in a substation: – (i) primary equipments and (ii) secondary equipments. Primary equipments include transformer, switchgear etc. Secondary equipments include protection, control and communication equipments. Further, secondary equipments are categorized into three levels in IEC-61850 standards. These are station level, bay level, and process level equipments. A typical diagram indicating the above three levels of equipment is shown in Fig. 4. Human Machine Interface (HMI) and ComU reside in the station level. HMI is the interface to the operator at the substation. Here, an operator can control and monitor the substation locally in the substation. ‘ComU’ is the interface between substation and Master Control Center (MCC). These devices are connected to bay level devices via station bus. The substation control system will communicate with protective devices and bay processing unit through station bus. The station bus is specified in the IEC-61850-8-1 part which is still under development.

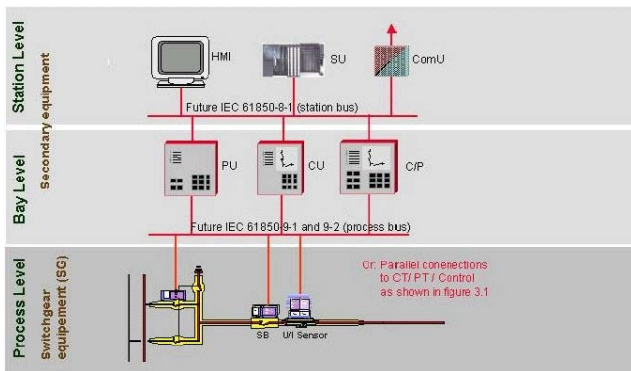

Fig. 4 Three level topology of substation equipment

A conceptual substation automation system of the future based on the IEC 61850 protocol is evolved and depicted in Fig. 5. In this conceptual scheme the station level equipment consists of station computer with a database, the operator’s workplace, interfaces for remote communication etc. Bay level equipment consists of control, protection and monitoring units per bay. Process level equipment consists of typically remote Inputs / Outputs, intelligent sensors and actuators as shown in Fig. 5. The station level equipment communicates with bay level equipment through station bus. Further, bay level equipment communicates with process level equipment through process bus as depicted in Fig. 5.

In the conceptual scheme, these two station and process buses are realized through the standard Local Area Network (LAN). Station bus is created by installing a multi-port Ethernet switch. Switch is a device in the computer network

that filters and forwards data packets between LAN segments. Generally Router, Human Machine Interface (HMI) and Engineering console are connected with Ethernet switch at station level. Router facilitates data communication between substation and Master Control Center (MCC). HMI enables the operator to monitor and operate the switching elements in the substation through Graphical User Interface (GUI) at substation level. The engineering console, as depicted in Fig 5, provides computer aided control decision, which can be implemented at primary equipment level through local HMI. If station level node has to communicate with process level node, it will send the message to bay level node through Ethernet switch. Ethernet switch will send the message to the appropriate node at bay level. This bay level node executes its function and forwards the message to process level node through Merging Unit. Merging Unit acts like a switch and provides the appropriate path to messages. Eventually, the function will be performed by the process level devices.

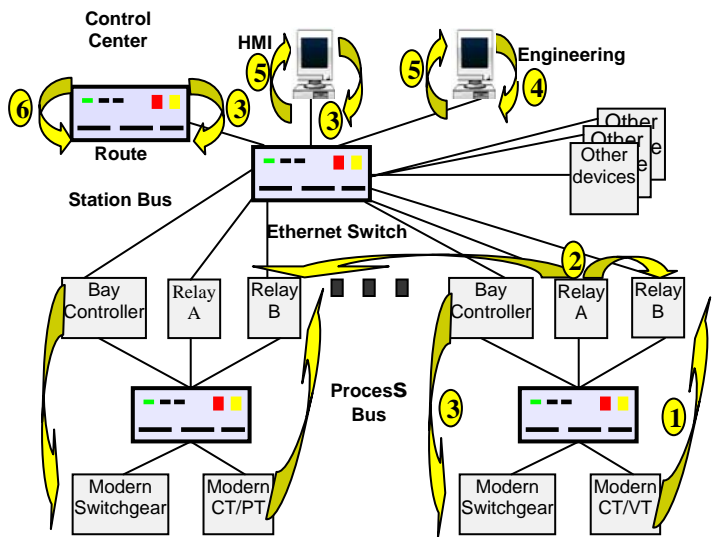

Fig. 5. Conceptual substation automation topology

The main focus of IEC-61850 protocol is to support the substation functions through the communication of (numbers in brackets refer to those in Fig. 5):

- Sampled values for CTs and PTs (1),
- I/O data for protection and control (2),
- Control and Trip signals (3),
- Engineering and configuration data (4),
- Monitoring and supervision signals(5),
- Data to Control-center (6),
- Time-synchronization signals, etc.

Other functions such as metering, condition monitoring and asset management are also supported in IEC-61850. Many functions are implemented in IEDs as shown in Fig. 5. Several functions may be implemented in a single IED or one function may be hosted by multiple IEDs. IEDs communicate among

each other by information exchange mechanisms of the standard. Therefore, functions distributed over more than one IEDs may also be implemented in the conceptual scheme.

V. STATION BUS AND PROCESS BUS

Many IEDs, that are used to take the decision for different functions of the substation, reside at bay level. They are connected to the primary equipments at the process level through process bus. The process bus eliminates the conventional hard wiring between the process level devices and bay level devices such as protection and control units.

The process bus communication is mainly based on the same services as that for station bus communication. There are only two additional services for the process bus. The first one is the fast and reliable exchange of tripping commands between protection devices and switchgear. The second one is the transmission of instantaneous values from electronic transducers. These two services need to be executed immediately on the communication stacks. For this reason, in the conceptual scheme, fast Ethernet has been chosen as basic technology for the process bus. All services that are common in station and process bus have been mapped in the same way. Due to high performance requirement for trip command and cyclic instantaneous data, it is not possible to map these services through MMS. Therefore, these services are directly mapped to Ethernet, which gives maximum performance and control over the transmission behaviour. This is realized through the serial unidirectional multi-drop point-to-point link and it is specified in IEC-61850-9-1.

VI. CONCEPTUAL DATA COMMUNICATION STACK

Station and process buses as described above have their different communication stacks. Communication stacks are defined according to the functionality of bus [8].

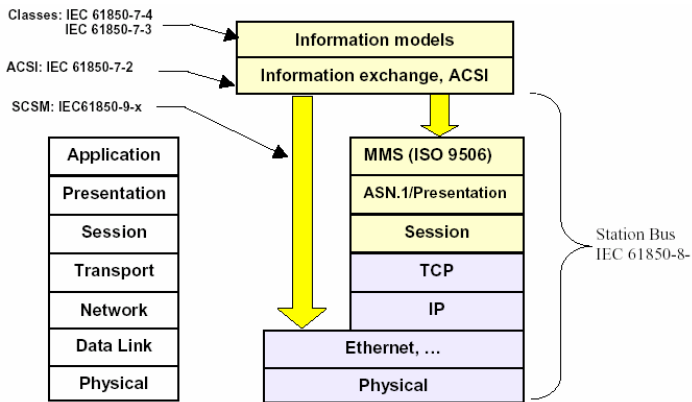

Fig. 6 Communication stacks of Station bus and Process bus

Object oriented approach has been used to model the power system information. Information models defined in IEC-61850-7-3 and IEC-61850-7-4 are used to build the basic variables and necessary classes used for communication. Further the necessary services such as “GetDataValue”,

“SetDataValue” etc. are defined in IEC-61850-7-2 and they are named as Abstract Communication Service Interface (ACSI). ACSI is a virtual interface to an IED to provide abstract communication services, for example, connection, variable access, unsolicited data transfer, device control and file data transfer, independent of the actual communication stack and profile used.

In the case of station bus, ACSI services are mapped to TCP/IP services using Manufacturing Message Specification (MMS) as shown in Fig.6. MMS is an internationally standardized messaging system to exchange real time data and supervisory control information between network devices and computer applications in a manner that is independent of: i) application function being performed ii) developer of the device or application. MMS services are applied to the presentation layer and rest of the stacks behaves as Open System Interface (OSI) model.

Process Bus is described by Specific Communication Service Mapping (SCSM). As described above, process bus is used for transmission of CT and PT instantaneous values. It is used for protection functions. So, fast communication between the logical nodes is required. Hence, in the conceptual data communication stack four layers (from presentation to network) are eliminated from the communication stack. Medium Access Control (ISO/IEC 8802.3) and Priority tagging/ VLAN according to IEEE 802.1Q are defined in the link layer of the stack. Fiber optic cable is preferred for physical layer in the process bus.

VII. CONCEPTUAL DATA CLASS MODEL

As described in the previous section, data have been categorized into different groups. Data classes represent meaningful information of applications located in automation devices. According to the classification, Common Data Classes (CDC) have been defined for basic communication structure for substation. These classes hold the member variables and the services provided to the logical node (related to variable). Fig. 7 presents a data class model and its conceptual adaptation. In this figure, the rectangle on the right represents the classes as per IEC 61850, whereas the rectangle on the left represents the instances or objects for that class in the conceptual substation automation.

As shown in the Fig. 7 MMXU1 is the object of logical node class MMXU. MMXU logical node is used for calculation of currents, voltages, powers and impedances in a three-phase system. This logical node contains the WYE as data class for data phV. Similarly, fourteen data classes are defined in logical node MMXU. WYE class is a collection of simultaneous measurement of values in a three phase system that represent phase to ground voltage. WYE class has data phsA of basic type Complex Measured Value (CMV). In the CMV, one of the member variable cVal of basic type Vector is defined. Vector contains the magnitude “mag” as well as angle “ang” of attribute type Analog value. Float type attribute of Analog value is used to measure voltage of phase A.

IEC-61850 has its own syntax to access the data as shown in Fig.7. In the conceptual model, a particular value is accessed by hierarchical dot notation. First we select the instance of the logical node MMXU given by MMXU1, and

