

# **PRESENT AND EMERGING TRENDS IN THE DEVELOPMENT OF STEAM TURBINE**

**G.C.Misra, AGM (STE) BHEL, Haridwar**

**Rajeev Rawat, Manager (STE) BHEL, Haridwar**

**Jatinder Mohan, Sr. Engineer (STE) BHEL, Haridwar**

## ***SYNOPSIS:***

*The acute shortage of power in India coupled with the limited primary energy sources and awareness of environmental pollution has led to ever increasing endeavor for the development of more efficient Steam Turbine power plants. For the higher ratings sets, even a small step increase in efficiency can result in major saving of resources and reduction in pollutant emission. As overall cycle efficiency is strongly dependent on Steam Turbine performance, continuous improvements are sought to increase the turbine efficiency. Further, the pursuit of higher cycle efficiency adopts two pronged approach i.e., improving Turbine Generator cycle efficiency by raising steam parameters and improving internal efficiency of turbine, generator and other equipment by incorporating advanced features in them.*

*Presently 210/250/500 MW sets form the backbone of power generation units in the country. BHEL Haridwar has introduced new rating sets of 270 MW, 525 MW and 600 MW in the sub critical range and 660 MW and 800 MW in the super critical range. These new ratings have been introduced to meet the criteria for accelerated rate of power generation, improved efficiency and thereby resulting in reduction in environmental pollution. These state of the art steam turbines are build on modular principle for high reliability, use new generation advance class blading and streamlined inlet and exhaust ports for higher efficiency and are provided with special features for high availability i.e., EHA based high pressure governing, minimum number of steam connection and arranging them in lower half. This paper highlights the salient features of new rating sets introduced by BHEL.*

*Also, to cope up with the enhanced market demand, BHEL Haridwar has initiated timely proactive measures to augment the manufacturing capacity of the plant. This will enable BHEL to manufacture & supply efficient and quality products to meet the customer requirements.*

## **1.0 INTRODUCTION**

Power is the key ingredient for economic growth of a country. From a meager 1330 MW capacity at the time of independence of India, generation capacity has grown steadily to 1,55,859 MW by Nov 2009. For a country of size like India with population of over 100 crores, the per capita power available is very inadequate which hampers the development in the country. Realizing this fact, Government of India has embarked upon to add 1,75,000 MW capacity in the 11<sup>th</sup> & 12<sup>th</sup> five year plans, out of which 78% will be thermal power. The objective of faster addition cannot be achieved by the present unit rating of 210/ 250 MW for near load centre power plants and 500 MW for base load plants. Need of the hour is higher capacity sets. While creating newer capacities cost of power generation, performance and environmental issues are also getting major focus.

To take care of these two aspects, high level of thermal efficiency is demanded from new thermal generating units. With the dual objective of bridging up demand and supply gap at faster pace and achieving higher efficiency, high power committee constituted by Government of India under the leadership of Central Electricity Authority have recommended installation of 660 & 800 MW sets utilizing supercritical technology.

BHEL, a global player in the power sector business has made a significant contribution in developing the country's thermal power generating capacity. Since the commissioning of the

first steam turbine in 1973, BHEL Hardwar plant has manufactured and supplied more than 200 steam turbines for the various rating of conventional power plants. Over the years the design of turbine has been continuously improved upon and steps have been taken to introduce new type/variants of steam turbines to meet the continuously changing market requirements. In line with this new ratings of 270MW and 525MW have been introduced with the prime objective of reducing cost per MW. Further, to gain advantage of CEA recommendation of 500+20% rating, BHEL Hardwar has developed the largest rating of 600MW with subcritical parameters. Also to keep pace with the latest developments and emerging market requirements, BHEL has equipped itself with the design and technology to supply steam turbine for 660 MW & 800 MW sets with Supercritical parameters.

## 2.0 NEW RATINGS DEVELOPED:

### 2.1 270 MW sets:

The 270 MW set consists of separate HP, IP & LP modules as in conventional 250 set. HP Turbine is of single flow design with double shell construction. Outer casing is of barrel type design. IP Turbine has casing mounted valves unlike the conventional 250 sets. Electro-hydraulic governing system utilizing high fluid pressure is envisaged for the regulation of turbine. LP turbine is of double flow design. Presently BHEL has more than 17 sets of orders of this rating in hand and many more are expected in the near future.

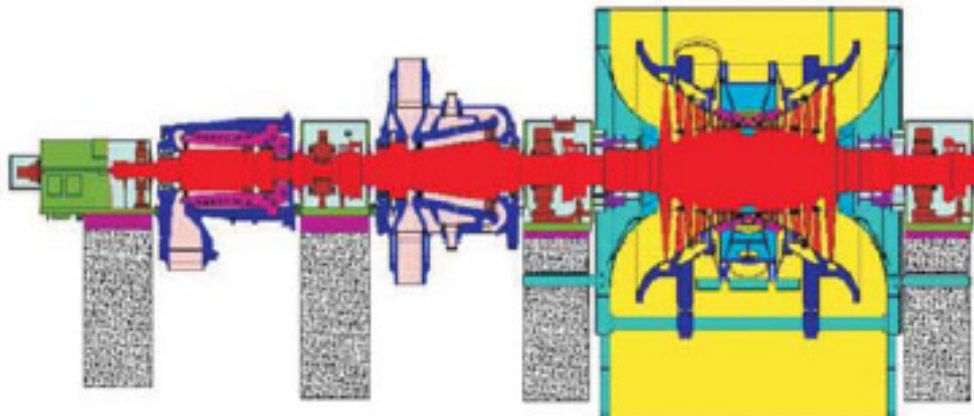

Fig.1: 270 MW set

### 2.2 525 MW sets:

The 525 MW set has separate HP, IP & LP modules as in conventional 500 set. HP, IP & LP Turbines are similar to the 500 sets in operation across the country. The turbine is equipped with electro-hydraulic governing system backed up with hydro-mechanical system. BHEL has already received many orders of this rating.

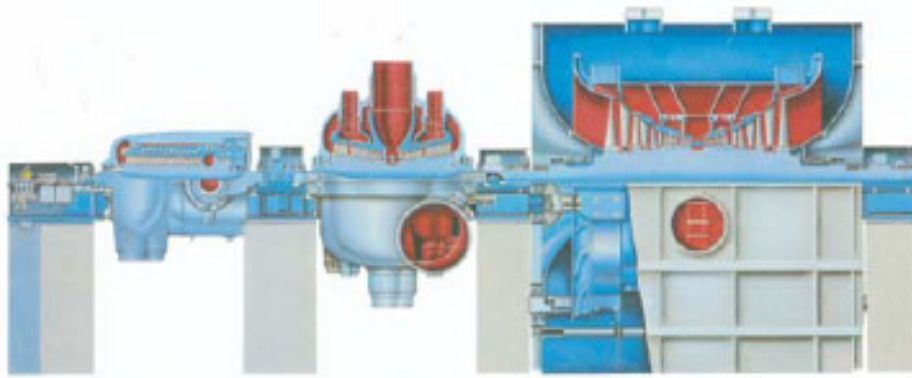

Fig.2: 525 MW set

### 2.3 600MW sets:

The 600 MW set is based on the proven modules of HP & IP being used in conventional 500 MW & LP module in use for conventional 250 MW set. It is a four cylinder machine, having one cylinder each of HP & IP and two cylinders of LP.

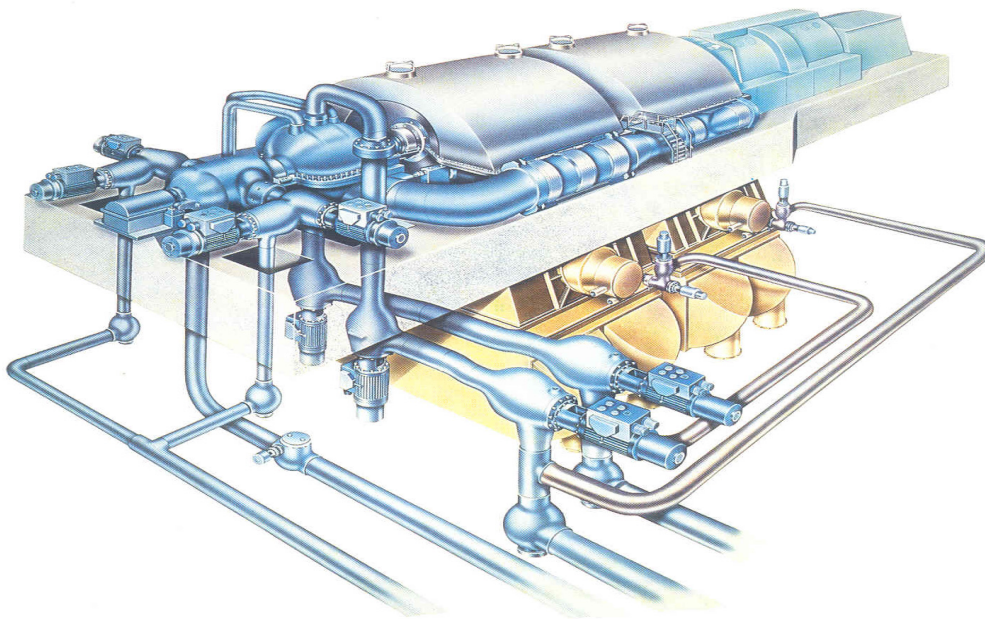

Fig.3: 600 MW set

To further boost up the customer's confidence, design of 600 MW has been vetted by our collaborator. The fact that this unit rating has got overwhelming acceptance from the utilities may be judged by order received for more than 14 sets within a short span.

### 3.0 STEAM TURBINES WITH SUPERCRITICAL PARAMETERS:

221.2 bar (225.6 ata) pressure and 374.15 °C temperature is called critical point of water/steam because at these parameters water changes to steam phase instantaneously (without any latent heat of evaporation). The steam turbines utilizing main steam pressure above this critical pressure are called super-critical turbines. Further increased steam conditions of 310 bar (316.2 ata) or over and 600 °C or over are called ultra super-critical turbines. The fact that thermal

efficiency of power cycle can be most effectively improved by raising the main and reheat steam condition was known from early times; however materials with adequate creep properties had been main constraint in adopting higher steam parameters.

### **3.1 Super-critical parameters and unit size**

With the transition from sub-critical to super-critical pressure and increased steam temperature the efficiency of the unit improves (or heat rate is reduced), however, the capital cost increases. The reduction of the heat rate leads to reduced fuel consumption resulting in cost savings over the entire service life of the power plant. The capitalized savings compared with additional investment cost justify economic viability. Both fuel cost and additional investment cost/MW reduces due to improved efficiency and reduction in cost/MW, if the unit size is also increased. The overall result shows the clear economic advantage of the super-critical with increase in unit rating above 500 MW.

### **3.2 Present status**

A global overview of new and upcoming power stations indicate trend towards super-critical steam parameters for large capacity units above 500 MW. A large number of sets above 500 MW are operating successfully or are under commissioning with steam conditions up to 300 bar (306 ata), 593 °C. Further developments are under way to use ultra super-critical parameters up to 350 bar (357 ata) & 650 °C.

### **3.3 Steam Turbines for Advance Steam Conditions**

The design of steam turbines employing supercritical steam parameters is not much different from the steam turbines with sub-critical parameters. Specific design changes are however needed in HP & IP turbine modules, main and reheat valves and their pipe connections which are exposed to elevated steam parameters. Realizing the higher efficiency as well as maintaining the higher reliability and availability is the prime criteria for the design of these turbines. Turbine design has to ensure that life of turbine and operational flexibility i.e. start up and loading capability of machine should in no way get affected by use of higher parameters. BHEL, Hardwar has acquired engineering and manufacturing know-how from M/s Siemens AG, Germany under technical collaboration agreement for steam turbines with supercritical steam parameters. The details of super critical steam turbine configuration for 660 MW & 800 MW rating are discussed in the following paras of the paper.

### **3.4 TURBINE DESIGN FEATURES**

A view of a large capacity steam turbine with super-critical steam parameters is shown in Fig. 4 (660 MW) & Fig. 5 (800 MW). It features tandem compounded separate HP, IP and LP modules. LP turbine modules may be one or more depending upon exhaust area requirements corresponding to capacity and back pressure. Modular principle is employed for the design of turbine cylinders which enable them to be used for a range of output and steam conditions by virtue of built-in flexibility in the design. It also promotes reliability and availability as time tested and well proven standard components are used as far as possible. All bearing pedestals are mounted directly on to the foundation separate from casings and only one bearing is positioned between two cylinders thereby leading to a compact design. Steam from IP turbine exhaust is carried to LP section through a single cross over pipe. All extraction connections for regenerative feed heaters and gland seal connections from casings are provided in the lower halves to facilitate maintenance. A brief account of the major assemblies with focus on unique features which enable the turbine suitable for advanced steam conditions is given as under.

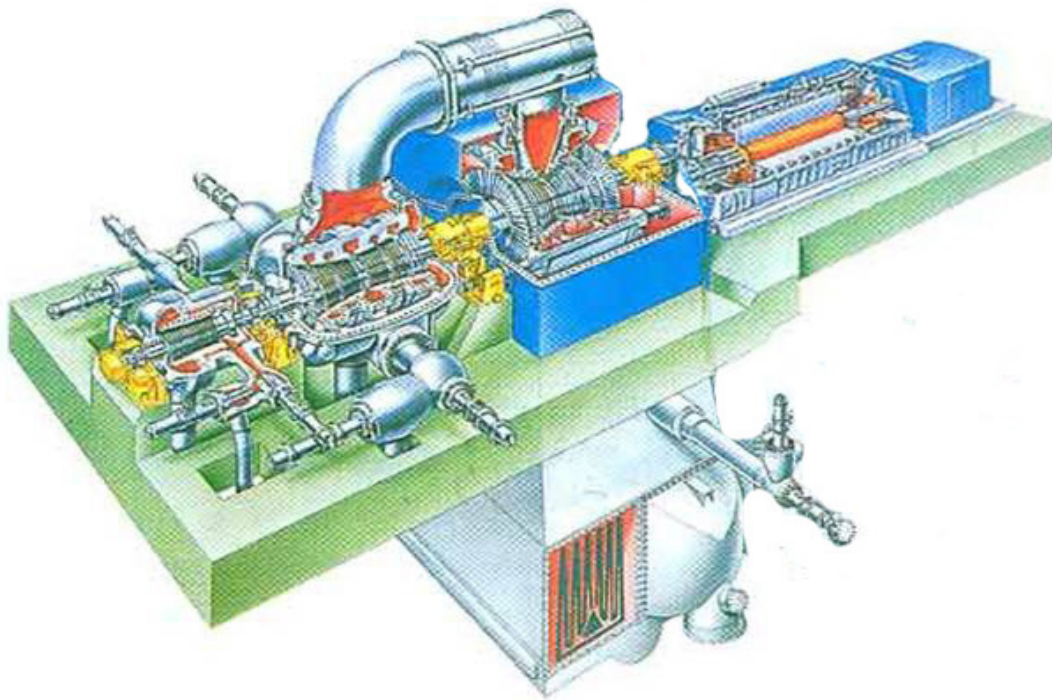

Fig. 4 660 MW steam turbine

### 3.4.1 HP turbine

HP turbine is of single flow design with double shell construction (Fig.6). Outer casing is of barrel type which makes design ideal for higher steam conditions. Barrel shape eliminates the heavy horizontal joint flange, resulting in reduced stresses and thermo-elastic design due to rotational symmetry thereby allowing higher main steam pressure and temperature. Steam flows into the turbine through two horizontally located main stop and control valves.

HP turbine is designed with full arc admission and impulse blading for first stage with tilted guide blades (Fig. 7) to expand the steam to pressure and temperature value lower than that would be achieved with a 50 % reaction stage. This arrangement leads to minimizing the rotor temperature, there by reducing the resulting stresses at highly stressed admission zone.

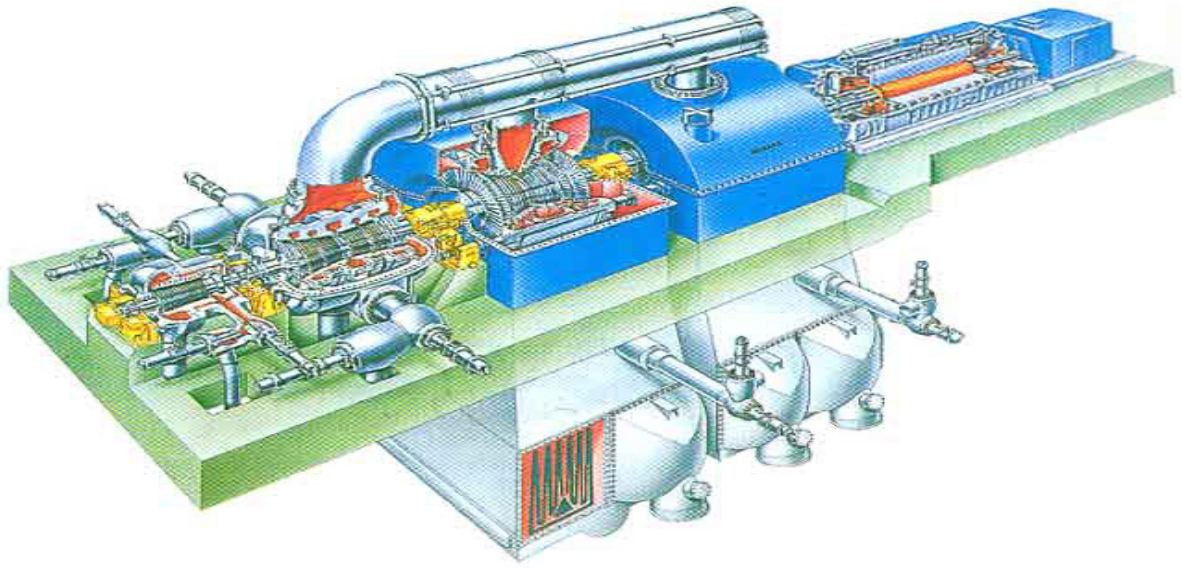

Fig. 5 800 MW steam turbine

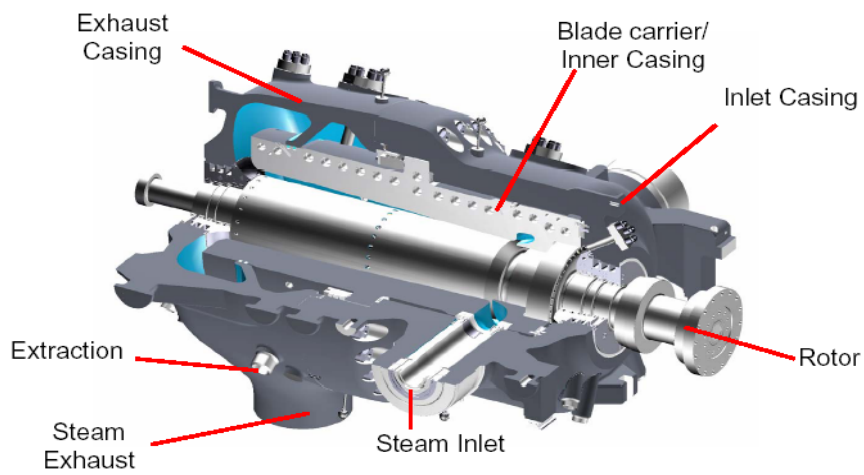

Fig. 6 Barrel type HP turbine

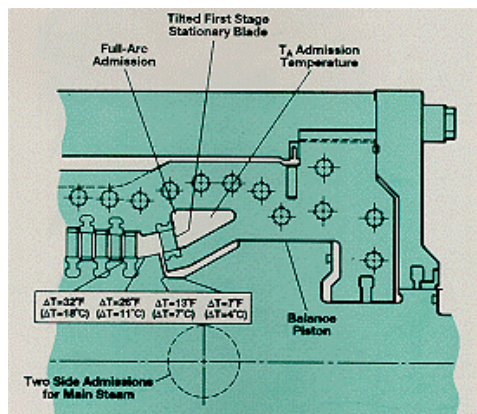

Fig. 7 HP turbine with tilted stationary blades

### 3.4.2 IP turbine

IP Turbine section is of double flow design with horizontally split double shell casings (Fig. 8). Reheated steam enters the turbine through two admission parts in the lower casing half and expands to LP inlet condition. As in HP turbine a tilted first stage guide blade arrangement with impulse blading is envisaged to achieve higher efficiency and reduce temperature at admission zone. In addition a heat shield with vortex cooling is also mounted at the inlet section (Fig. 9). This admission design lowers the rotor center temperature. The cooling steam flow through four properly sized tangential holes (nozzles) and cools the rotor dynamically since the vortex steam temperature is low due to its expansion to high kinetic energy level. A significant temperature reduction is achieved by this arrangement. IP rotor is machined from single piece integral forging and built without through core hole which helps in reducing the stresses in inlet zone.

### 3.4.3 LP turbine

Double flow, multi shell construction is used for the design of LP turbine (Fig. 10). Steam is admitted through a single connection at top. LP outer casing is welded to condenser which rests on the base plate. As a result weight of LP outer casing is not transmitted to turbine foundation. LP inner casing is supported on the horizontal arms that extend from pedestals and pass through outer casing. The supporting pedestal arm and outer casing are connected through a

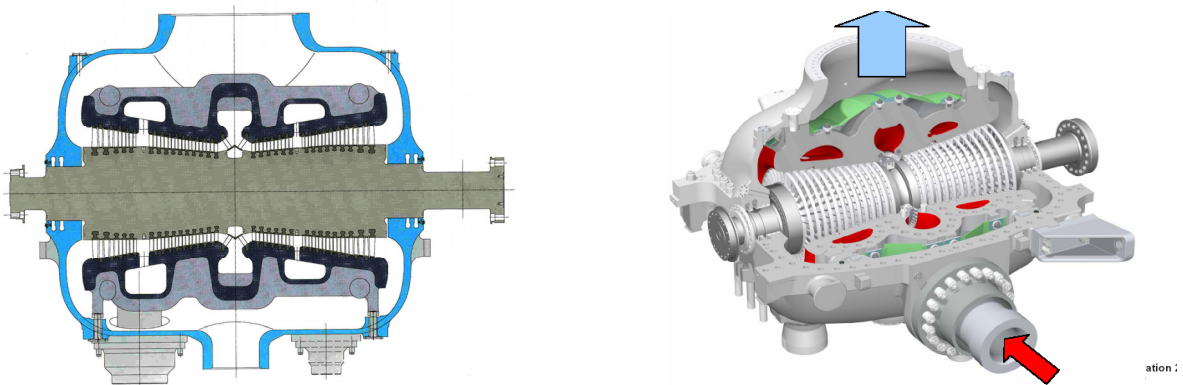

Fig. 8 IP turbine

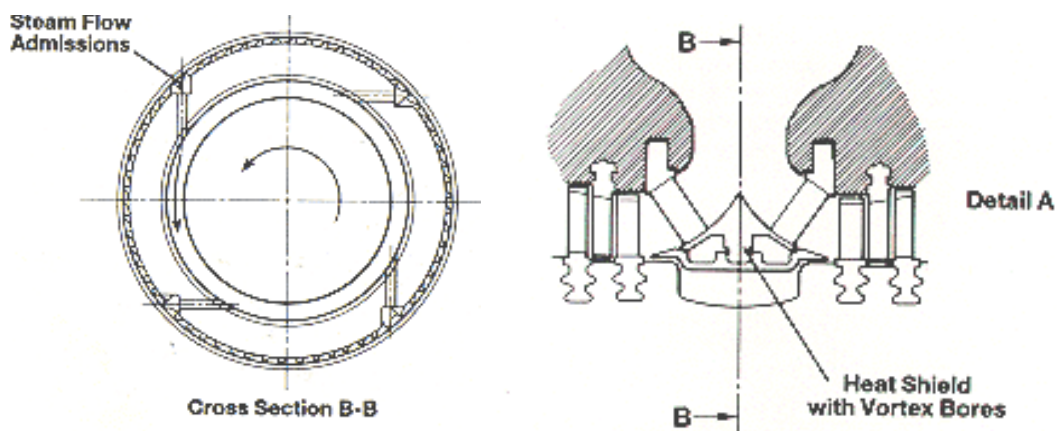

Fig. 9 IP turbine with tilted stationary blades and heat shield with vortex cooling

compensator (Fig. 11). The steam inlet connection at admission section is likewise connected to LP inner casing through a compensator. This arrangement makes the LP inner casing independent of outer casing which prevents the outer casing distortions from being transferred to LP inner casing.

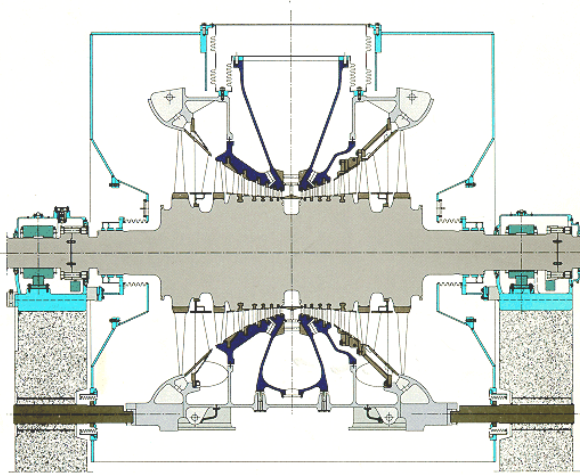

Fig. 10 Cross Section of LP Turbine

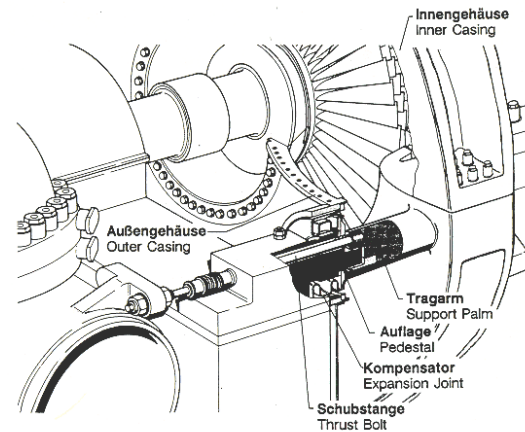

Fig. 11 LP Turbine Inner Casing

### 3.4.4 Blading

New generation blading consisting of 3DS blades in HP,IP initial stages; cylindrical profile TX-blades in HP,IP middle and LP drum stages; twisted profile F-blades in HP,IP rear stages and advance LP blading for last three stages with Banana guide blades are envisaged for the turbine.

### 3.4.5 Turbine governing system

As large capacity units are employed for base load operation, turbine is equipped with throttle type governing system. Electro-hydraulic governing system utilizing high fluid pressure (160 bar) is envisaged for regulation of turbine. Use of high pressure reduces the size of actuators & bulky oil piping leading to compact and simplified plant layout. In addition, replacement of many mechanical equipments of low pressure system by state of the art electronics in new system would benefit in faster response & higher redundancy.

## 4.0 CONCLUSION

Growing interest in environmental protection and making best use of available resources, the trend in coal fired steam power plant world over is toward higher efficiency through employing advance steam parameters. Further, as coal based power generation is going to remain backbone of power generation in India, super-critical steam turbines of 660 MW & 800 MW rating for base load power plants are necessary to achieve the desired rate of capacity addition and also to improve the efficiency of power generation and to minimize pollutant emissions. To meet the challenges of growing demand & enhanced targets BHEL Haridwar has undertaken major initiative to augment the existing manufacturing facilities in a big way. This upgradation/augmentation is also planned to meet the requirements of supercritical sets in future.